

Wiring Diagrams 1981

Section
3

Group
39

Wiring Diagrams

1981 Models

VOLVO

Contents

NOTE:

Diesel circuitry is generally = GLE

Fuses and related circuits	DL, GL, GLT.....	2
	GLE, Coupe	3
How to use the diagrams		4
Alternator circuits (main wiring)		6
Starting circuits		8
Diesel: starting and glow plug system		10
CI fuel injection system	B21F, B23E	12
	B28F	14
Oxygen sensor feedback system (Lambda-sond)	B21F	16
	B21F-Turbo	18
	B28F	20
Ignition system, w. breaker points	B21A,	22
breakerless electronic	B21F, B21F-Turbo ...	24
	B23E (Canada)	
computer controlled	B21F-MPG	26
breakerless electronic	B28F	28
Constant Idle Speed (CIS) System	B21F, B21F-MPG	30
	B21F-Turbo	32
	B28F	34
 Lights		
Headlights		36
Parking lights, tail lights,	DL, GL	38
license plate lights	GLE, GLT, Coupe	40
Parking light, tail lights, license plate lights,	Wagon	42
Brake lights	DL, GL	44
	GLE, GLT, Coupe	46
	Wagon	48
Back-up lights, manual transmission	DL, GL	50
	GLE, GLT, Coupe	52
	Wagon	54
automatic transmission	DL, GL	56
	GLE, Coupe	58
	Wagon	60
Interior light	DL, GL, GLT	62
Rear interior light	Wagon	64
Delayed interior light	GLE, Coupe	66
	Coupe	68
Engine compartment light, trunk light		70
Glove box light		72
Instrument lights, lights on controls		74

TP 30316/1

4.500.09.81
Printed in U.S.A.

Items associated with instrument panel

Instrument cluster	6
Oil pressure gauge	78
Voltmeter	80
Ambient temperature gauge	82
Clock	84
Cigarette lighter	86

Warning systems

Bulb failure warning system	88
Brake failure warning system	90
Seat belt warning system	92
Ignition key and light warning buzzer	94

Signals

Turn signals and hazard warning flashers	96
Wagon	98
Horn	100

Wiper/washer

Windshield wiper and washer	102
- operation modes	104
Tail gate window wiper and washer	
- With interval relay	106
- Without interval relay	108

Electrical equipment

Overdrive	110
Heater blower	112
Air conditioning	114
- operation modes	116
Rear demist	118
Electrically heated driver's seat	120
Electrically heated passenger seat	122
Electrically operated side mirrors	124
Window lifts, 2-door	126
4-door	128
Central lock, 4/5-door	130
- operation modes	132
Coupe	134
- operation modes	136
Cruise control	138
- operation modes	140
Radio and power antenna	142
Electric cooling fan	144
Locations for relays, buzzers, control units etc	146
Locations for Electronic Control Units	148
Wiring harnesses	149

Master wiring diagram

Contents	153
Alphabetical index	154
Wiring diagrams and locators	156
Master wiring diagram, fold-out sheet	End of manual

Fuses and related circuits DL, GL (GLT except rear lights)

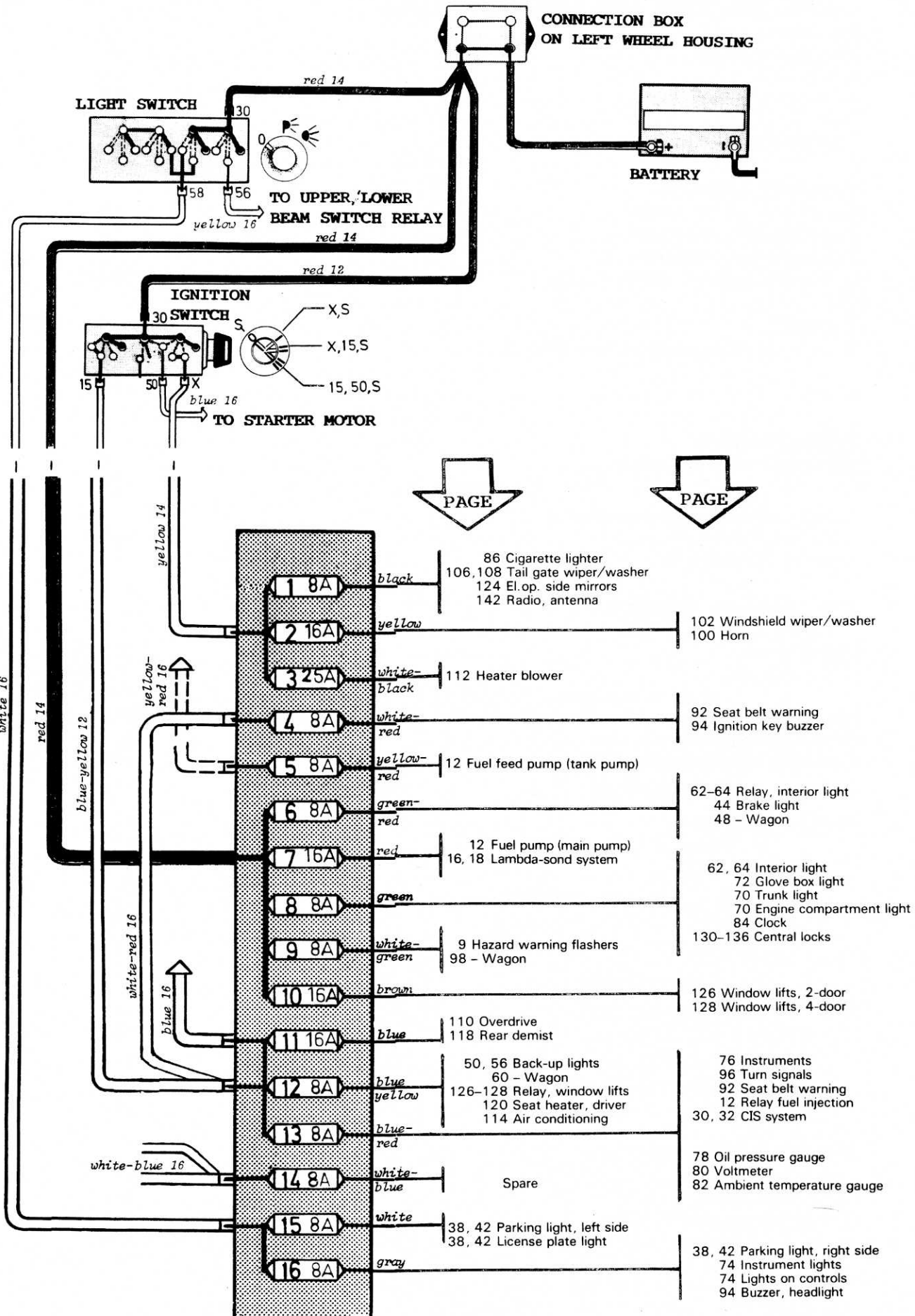

Fuses and related circuits GLE, Coupe (GLT: rear lights)

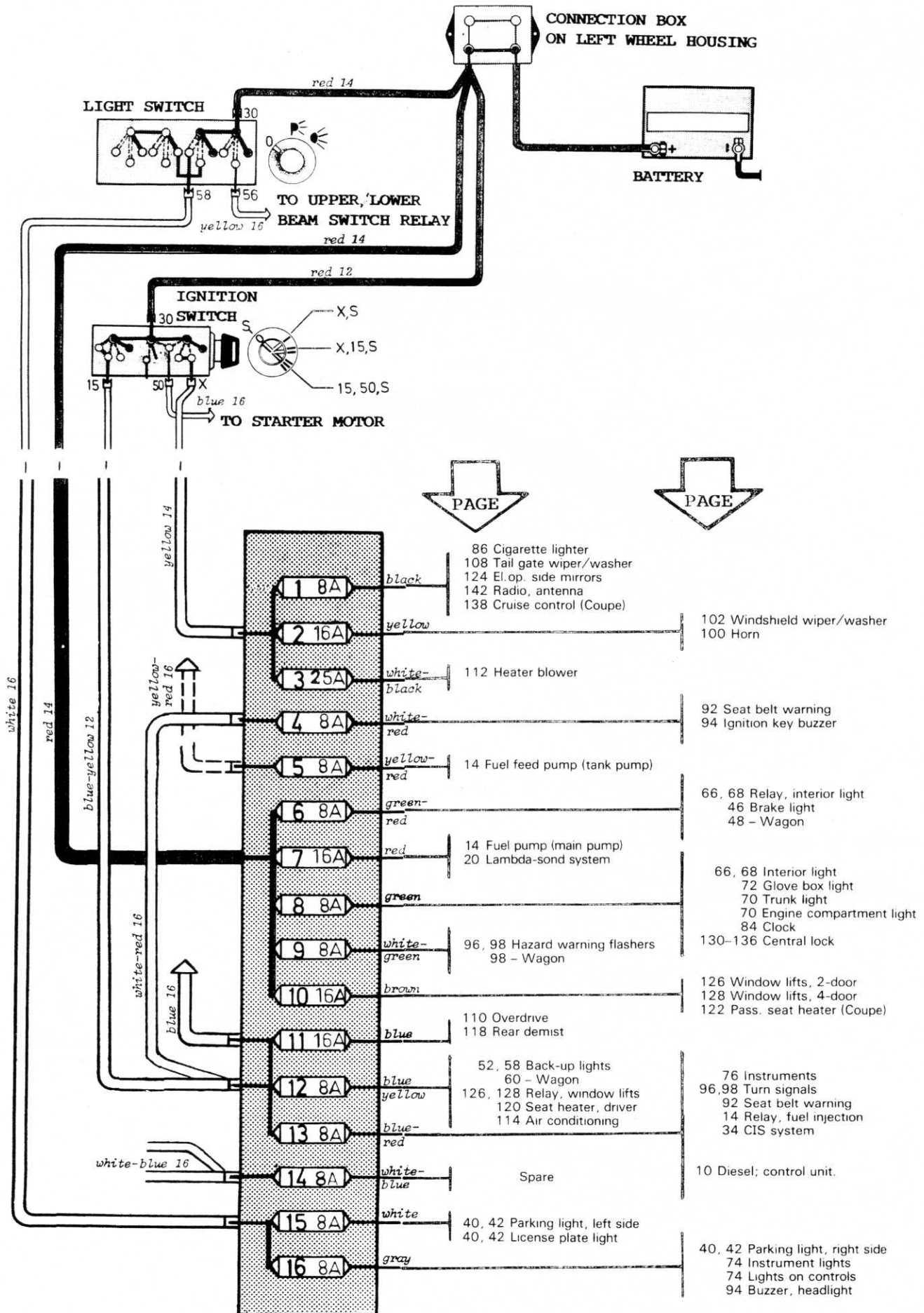

How to use the diagrams

Left page

Illustrates the **electrical circuit**.
De-energized condition is shown at top of page. Energized condition(s) at bottom of page.

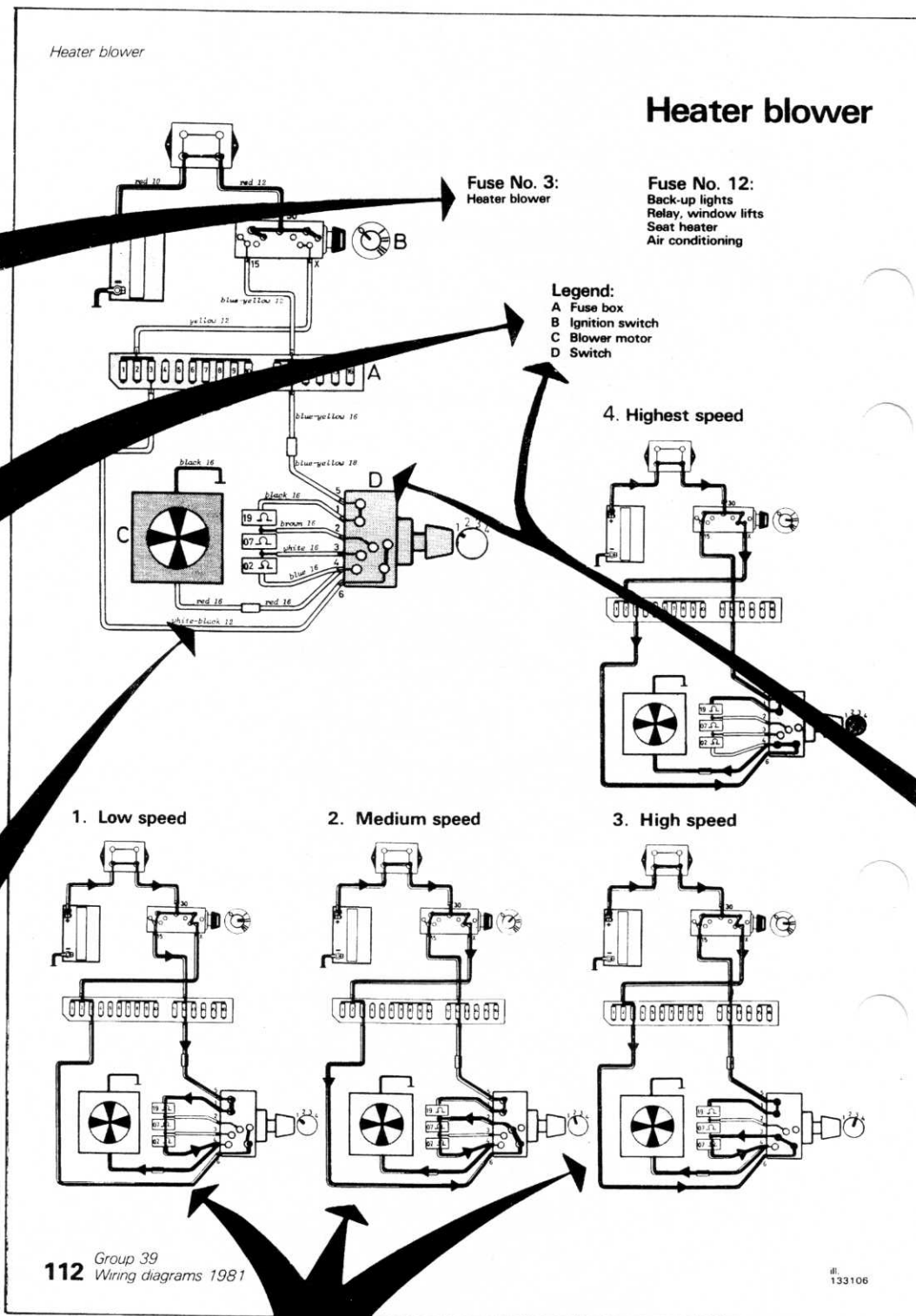

How to use the diagrams

Right page

Illustrates the physical location of the components in the vehicle and the exact routing of the wiring harness. Each component is shown with terminals and connections.

Heater blower

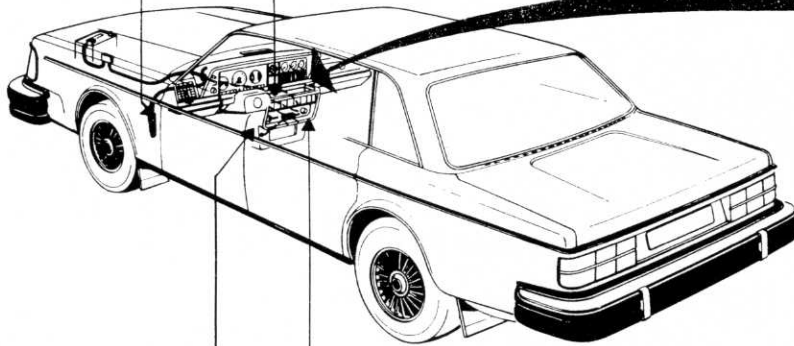
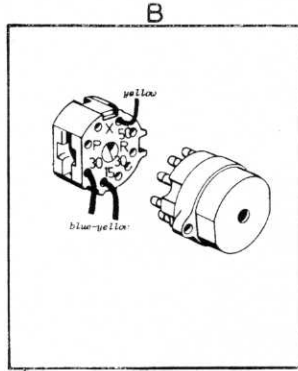
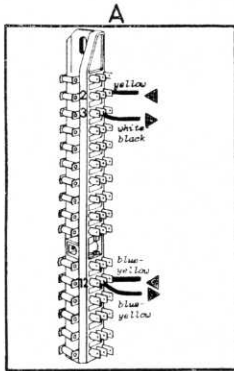

Component location and routing of wiring harness

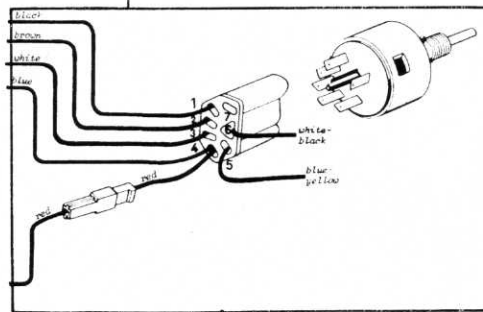
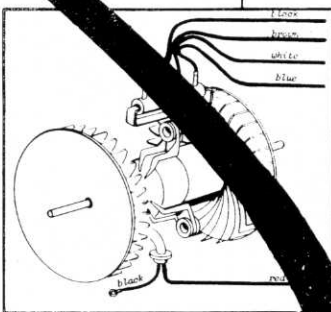

Component terminals and wire connections

Ill 133107

Group 39
Wiring diagrams 1981 113

Letters facilitate referencing components on either page

Alternator circuits

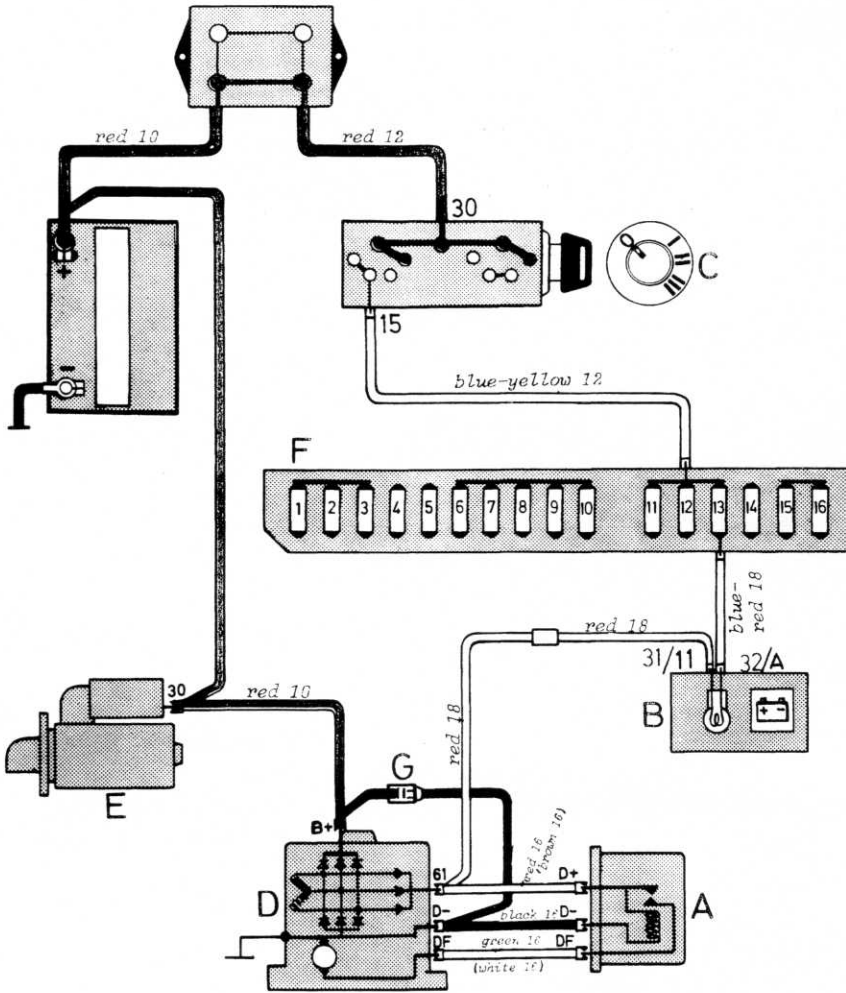

Fuse No. 13:
 Instruments
 Turn signals
 Seat belt warning
 Relay, fuel injection
 Solenoid valve (carburetor)

Legend:
 A Voltage regulator
 B Instrument cluster
 C Ignition switch
 D Alternator
 E Starter motor
 F Fuse box
 G Capacitor

NOTE: Voltage regulator shown in schematic is symbolic of and not actual regulator. A solid state regulator is presently used.

Ignition ON
 (engine not running)

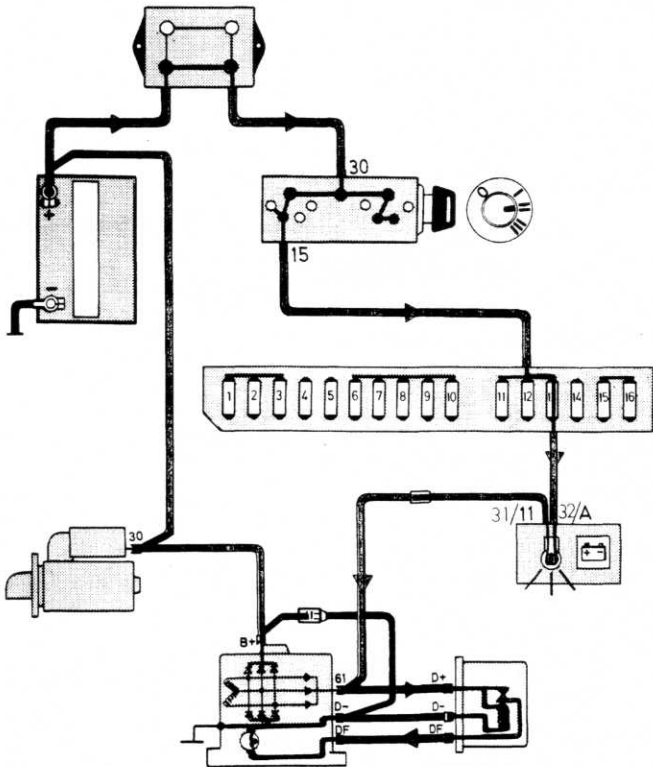

Alternator charging

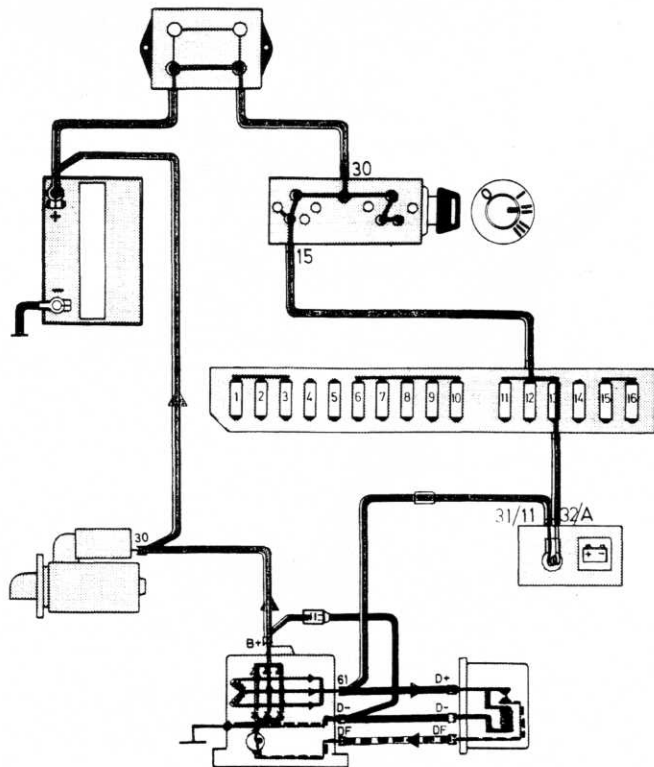

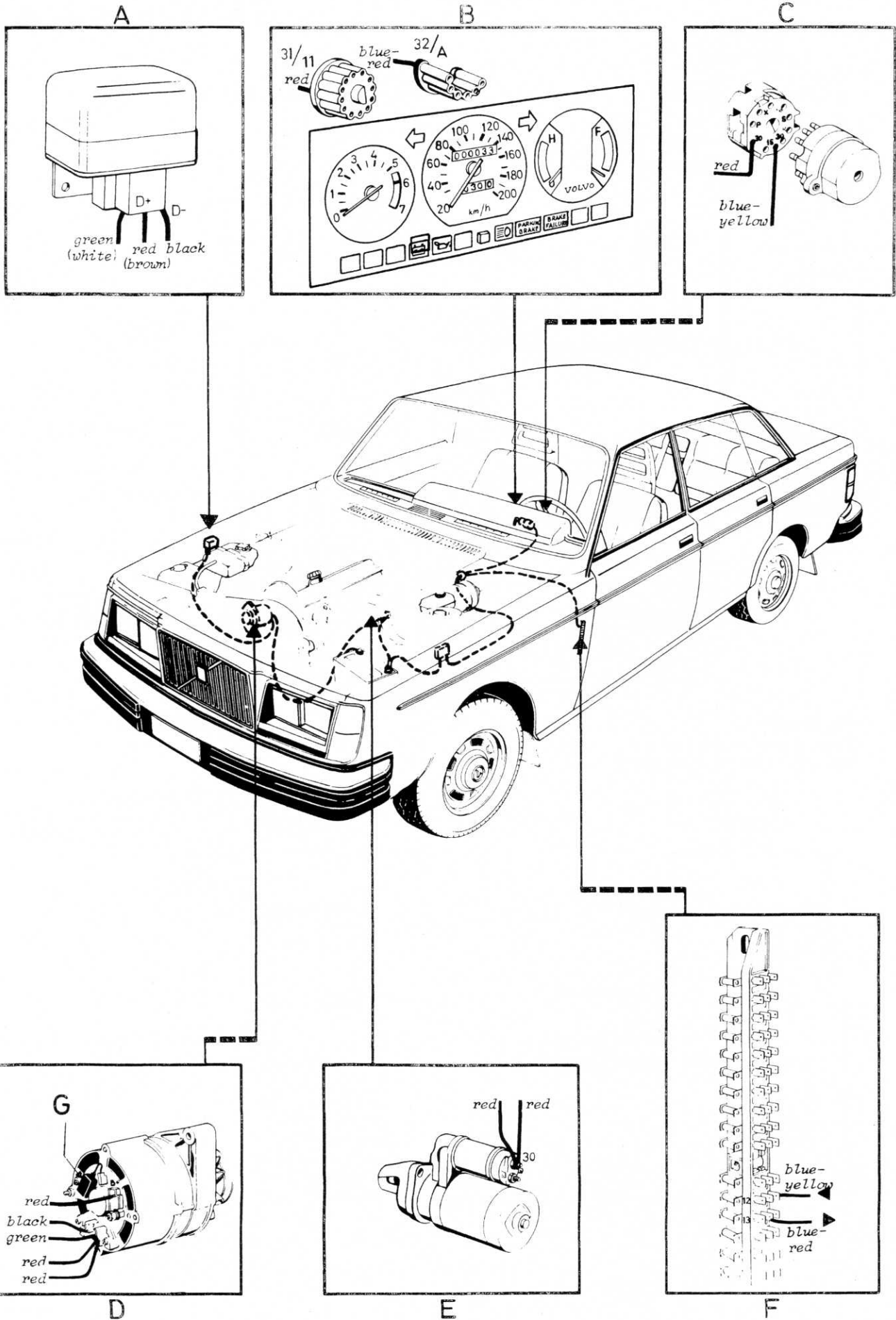

Starting circuits

Legend:

- A Ignition coil
- B Remote starter pick-up point
- C Ignition switch
- D Starter motor
- E Connector
- 1 Manual transmission
- 2 Automatic transmission
- F Start inhibitor switch (automatic transmission)
- G Ballast resistor

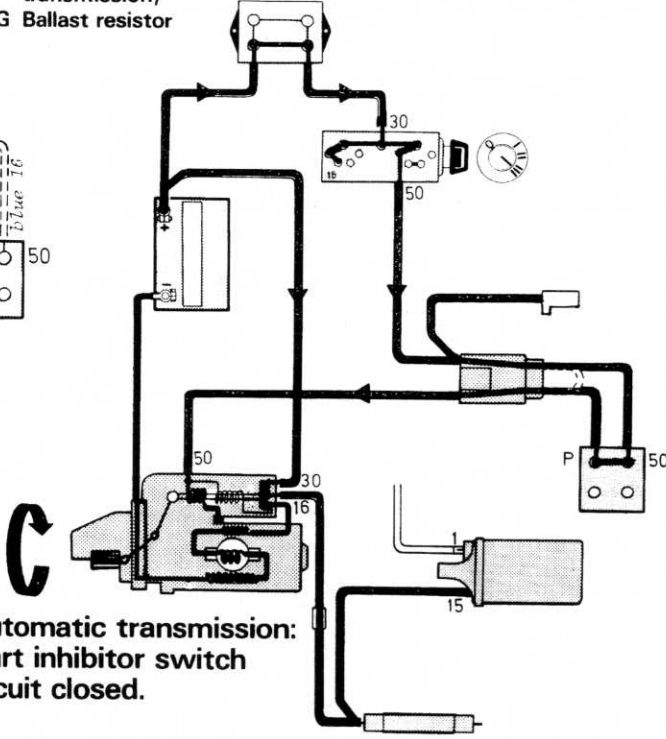
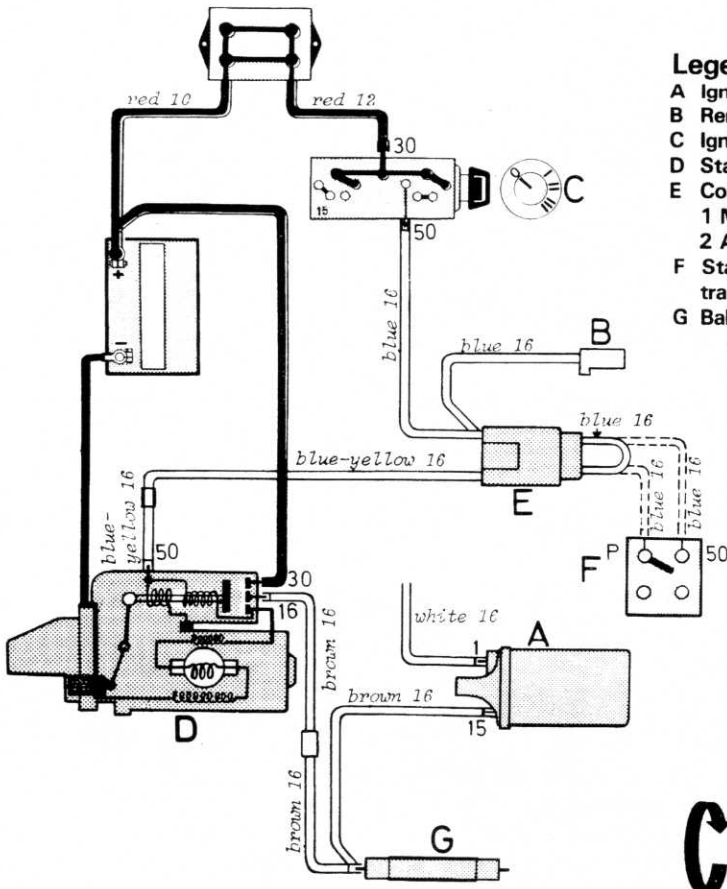

**Automatic transmission:
start inhibitor switch
circuit closed.**

First step:

Solenoid pushes starter motor gear into contact with ring gear.

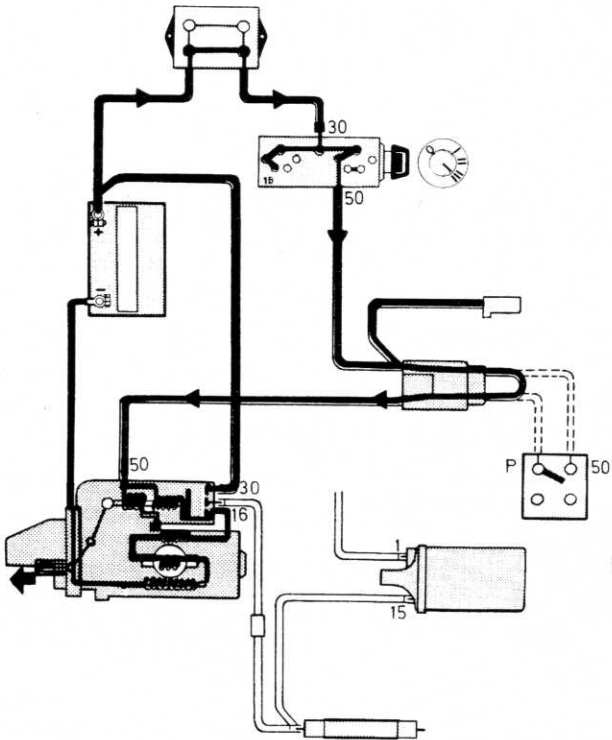

Second step:

Gears connected, starter motor contacts close, starter operates.

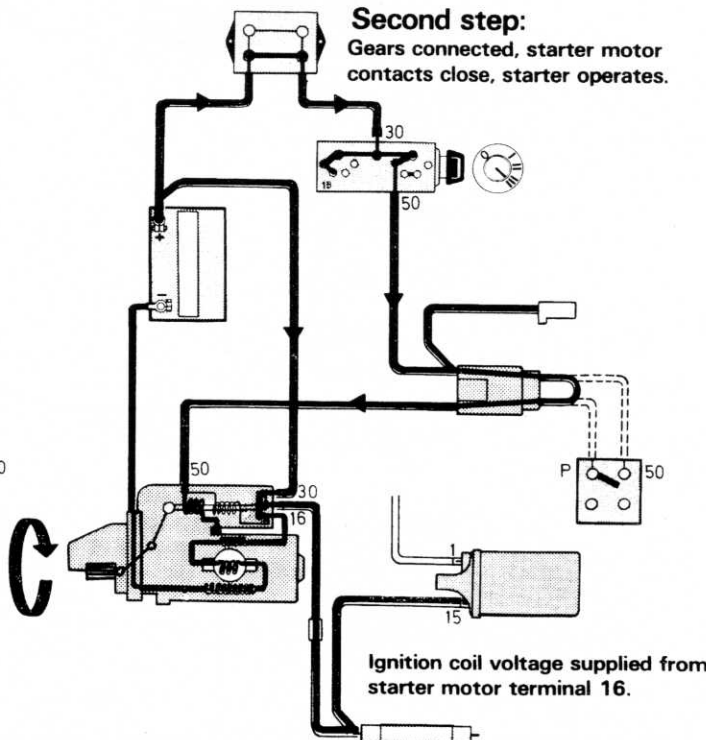

Ignition coil voltage supplied from starter motor terminal 16.

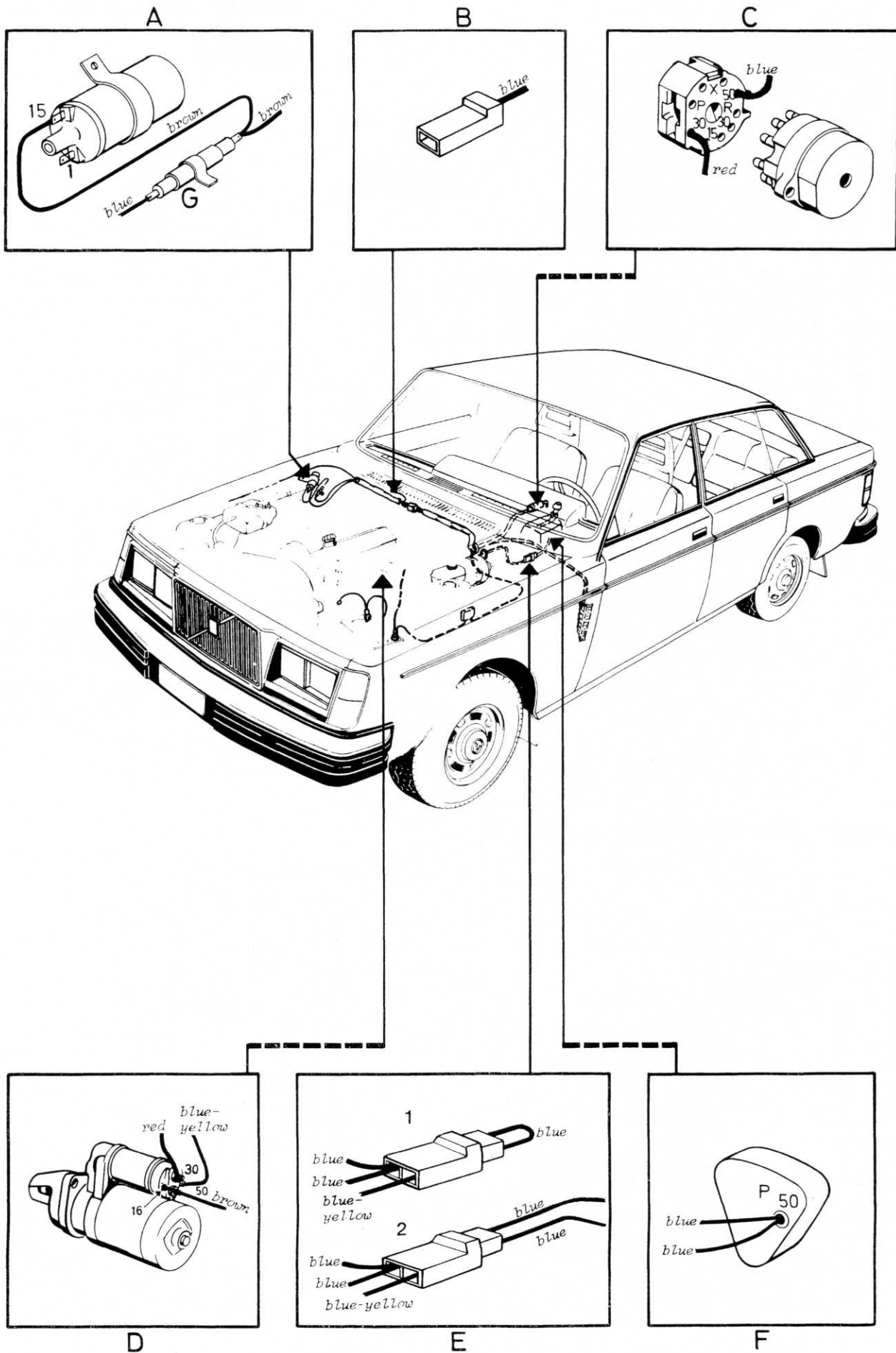

Glow plug system Diesel

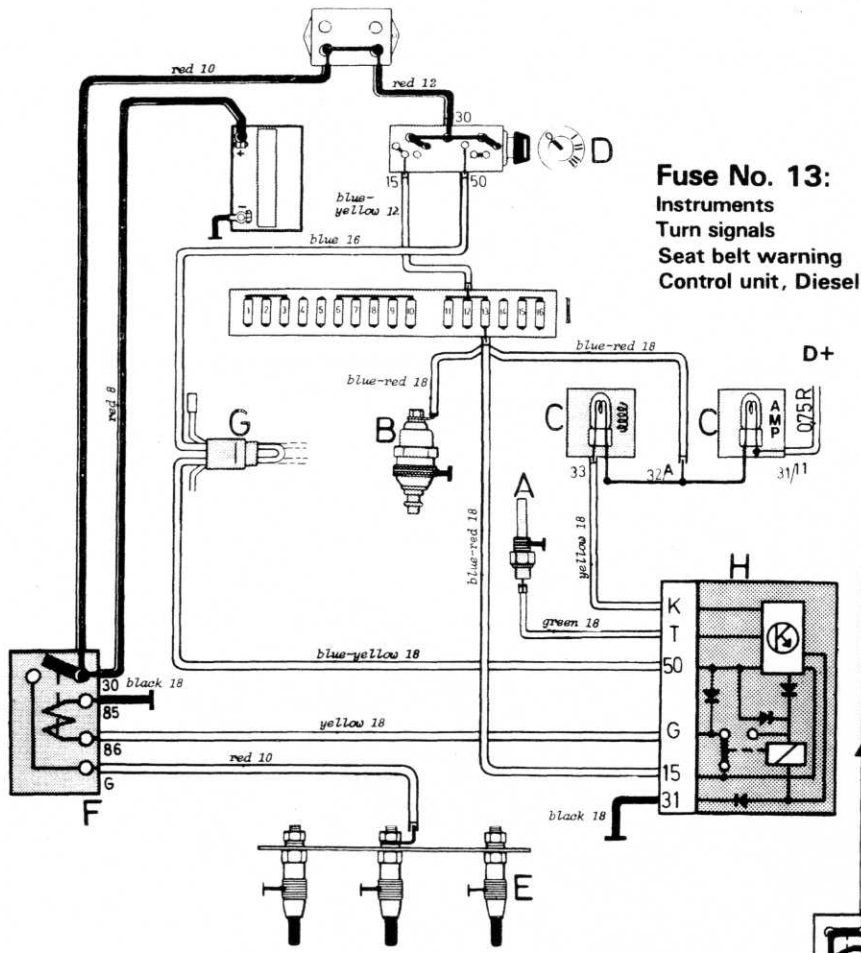

Fuse No. 13:
Instruments
Turn signals
Seat belt warning
Control unit, Diesel

Legend:
A Temperature sensor
B Stop valve
C Indicator light
D Start switch
E Glow plug
F Glow plug relay
G Remote starter pick-up point
H Control unit
I Fuse box

Start key ON
Coolant temperature
below +50°C = 122°F

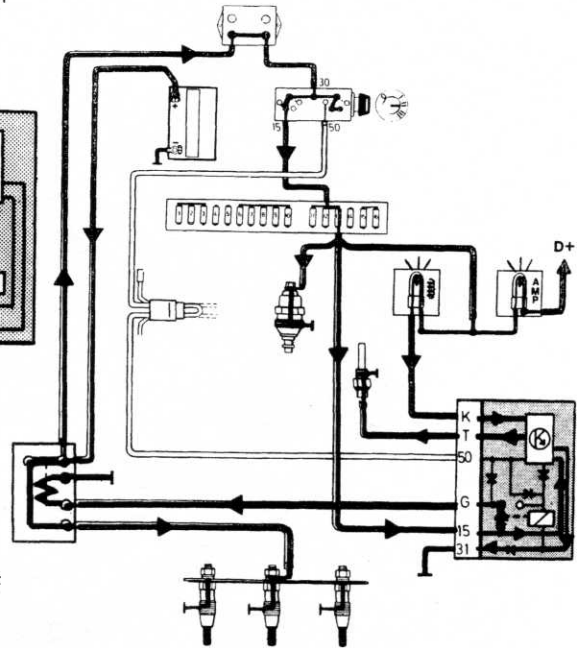

Starter motor operating

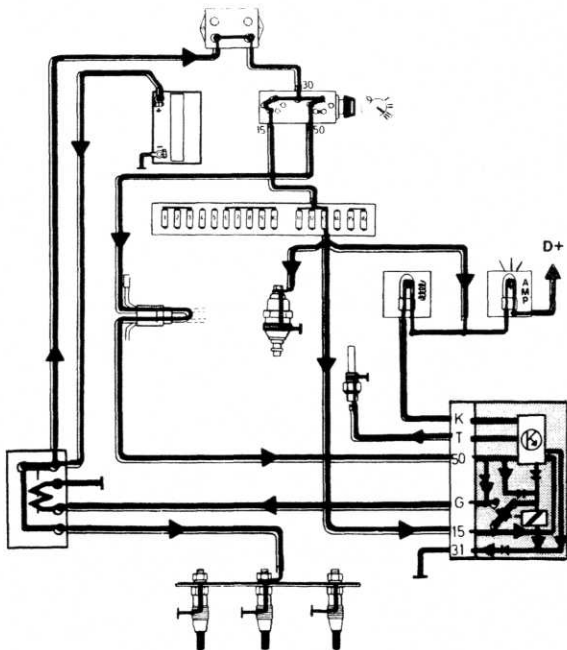

Engine running

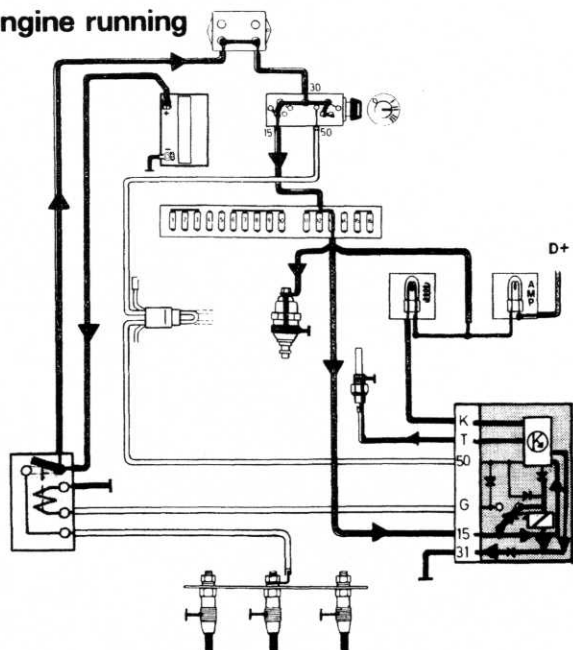

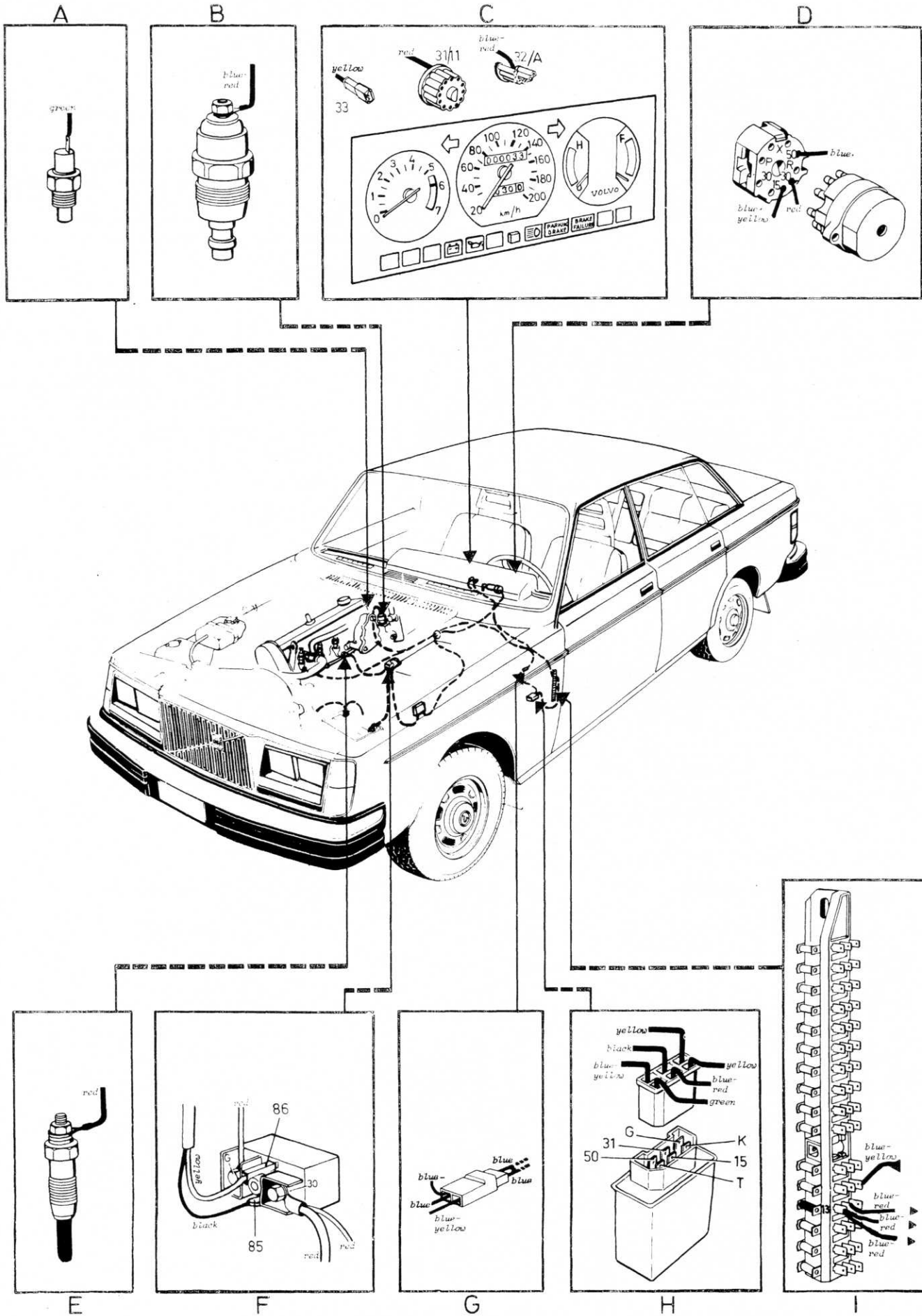

Adam's Car

CI fuel injection system B21F, B23E

Legend:

- | | |
|------------------------------|---|
| A Thermal time switch | K Overload protection switch (Turbo only) |
| B Fuel feed pump (tank pump) | L Control pressure regulator |
| C Connector | M Cold start injector |
| D Connector | N Ignition electronic module |
| D ¹ Capacitor | O Distributor |
| E Starter motor | P Auxiliary air valve |
| F Ignition switch | R Ignition coil |
| G Fuel pump (main pump) | |
| H Fuse box | |
| J Electronic pump relay | |

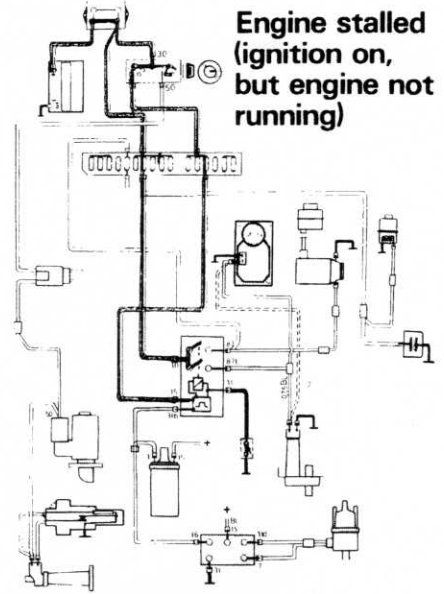
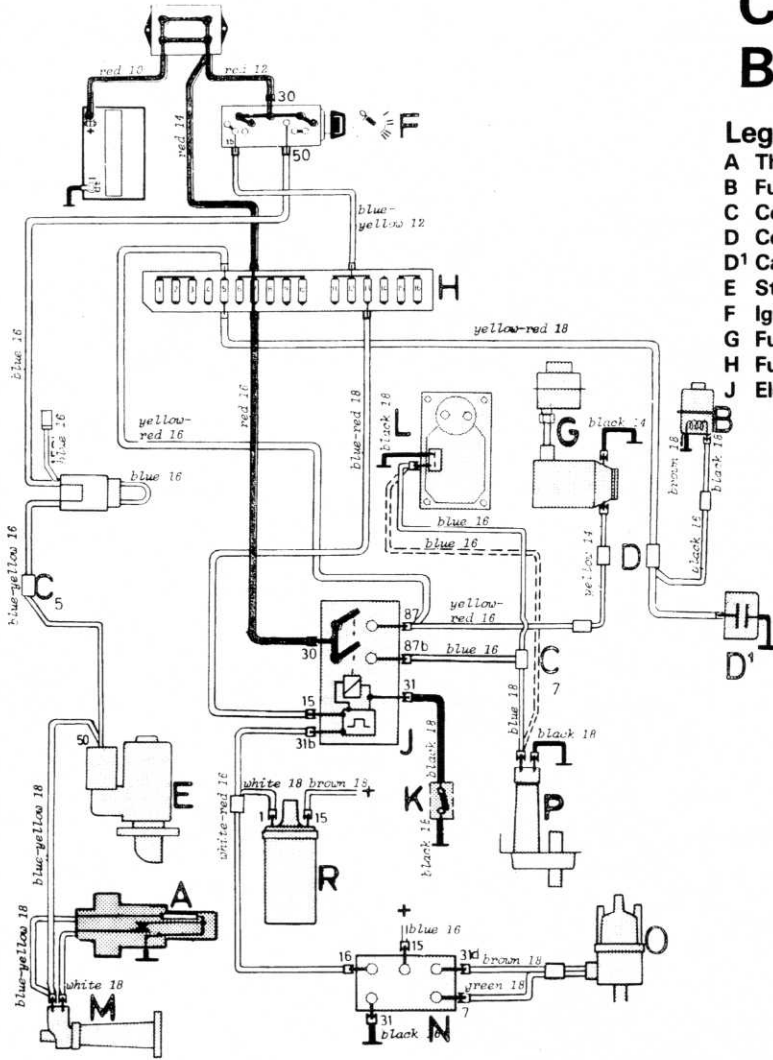

Fuse No. 5:
Fuel feed pump
(tank pump)

Fuse No. 7:
Fuel pump
(main pump)

Fuse No. 13:
Instruments
Turn signals
Seat belt warning
Relay, fuel injection

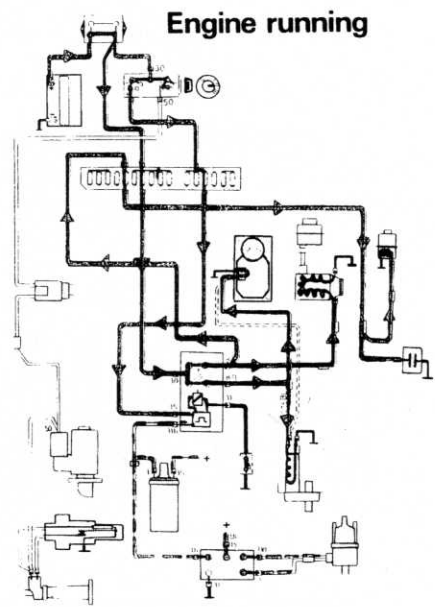
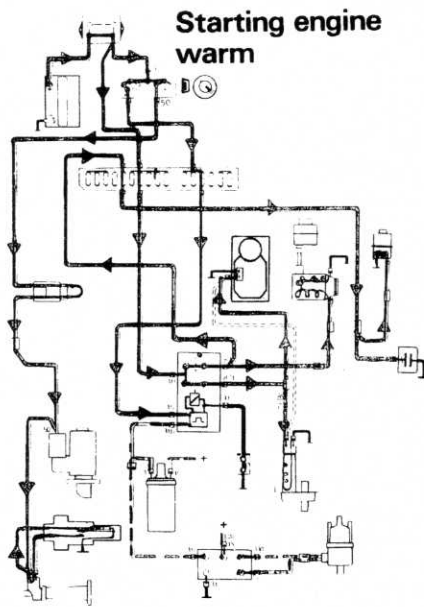
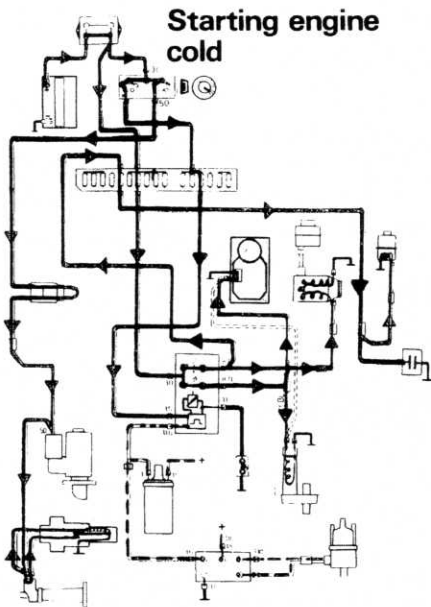

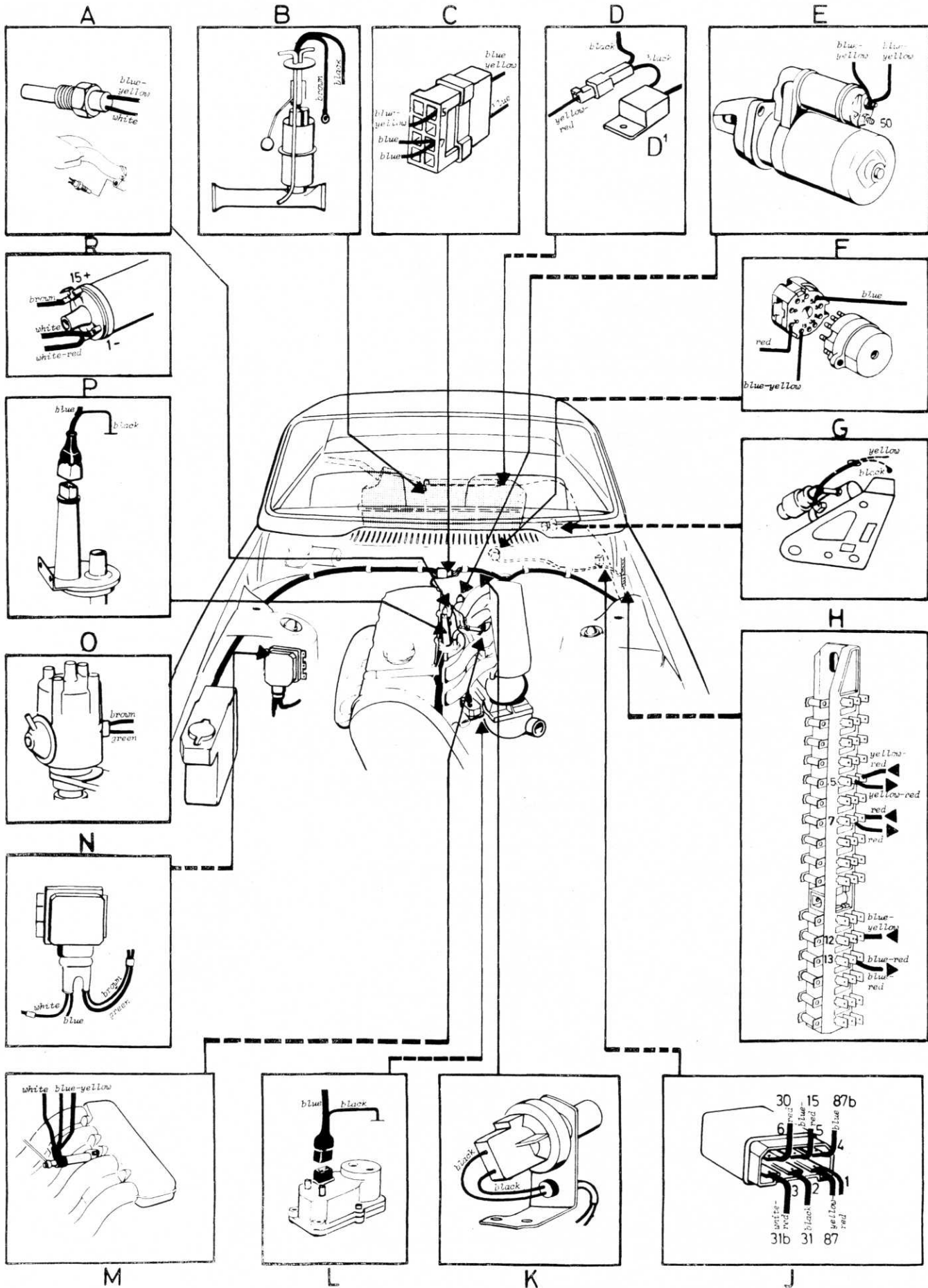

CI fuel injection system B28F

Legend:

- | | |
|------------------------------|------------------------------|
| A Fuel feed pump (tank pump) | J Cold start injector |
| B Connector | K Control pressure regulator |
| C Capacitor | L Distributor |
| C Electronic pump relay | M Auxiliary air valve |
| D Ignition switch | N Ignition coil |
| E Fuel pump (main pump) | O Impulse relay |
| F Starter motor | P Ignition electronic module |
| G Fuse box | R Connector |
| H Thermal time switch | |

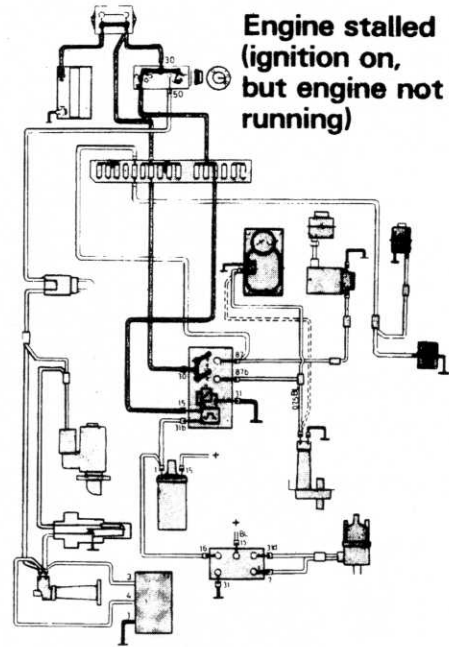
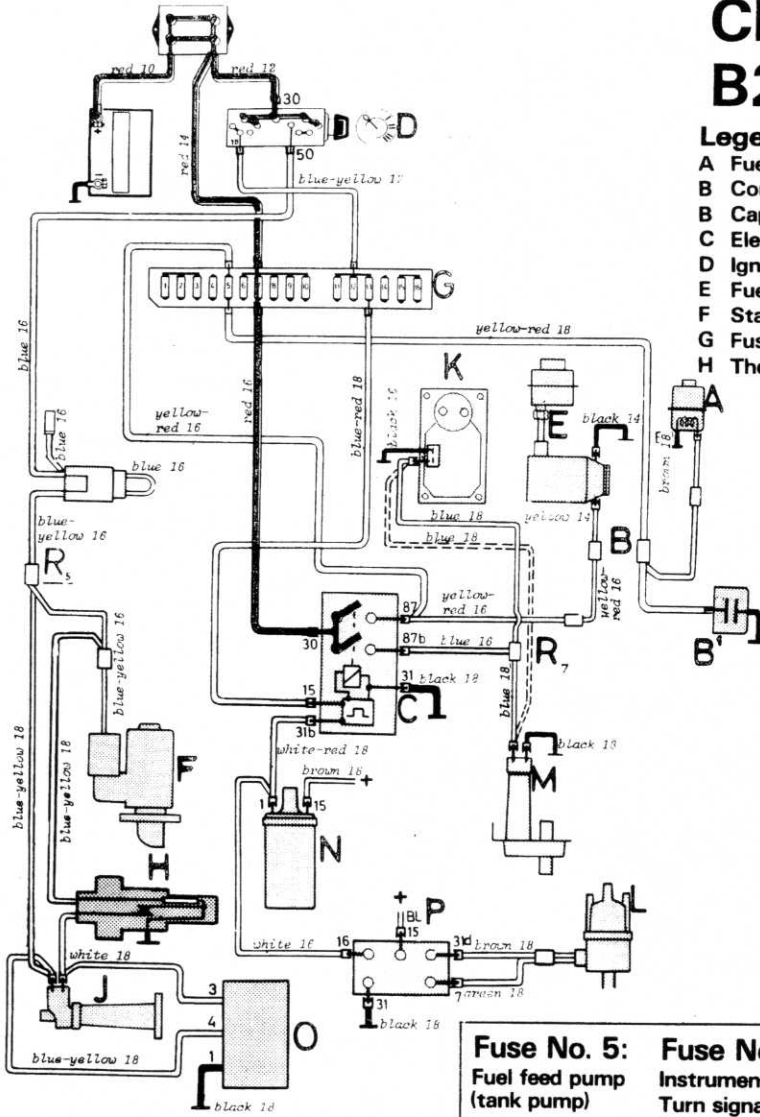

Fuse No. 5: Fuel feed pump (tank pump)
Fuse No. 7: Fuel pump (main pump)
Fuse No. 13: Instruments, Turn signals, Seat belt warning, Relay, fuel injection

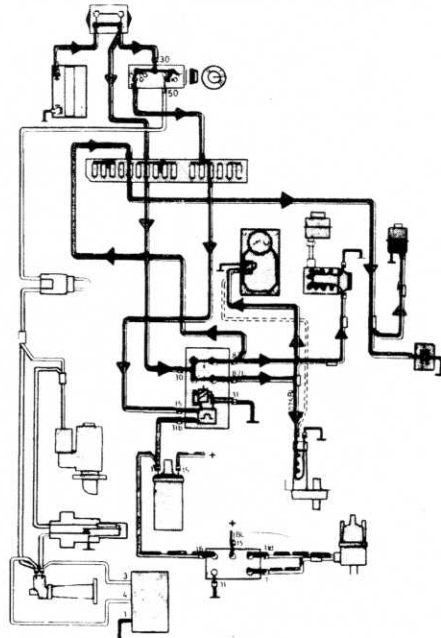
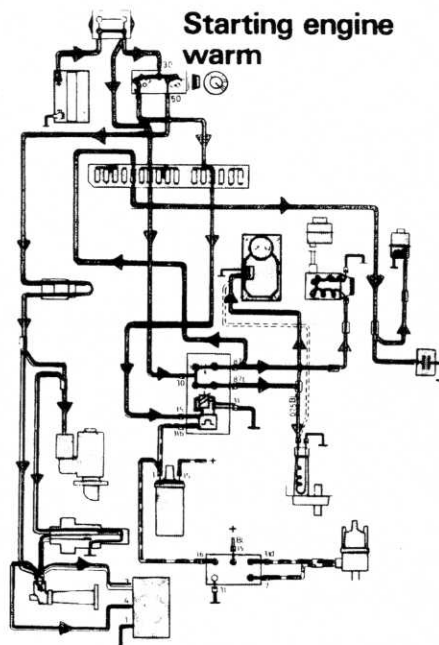
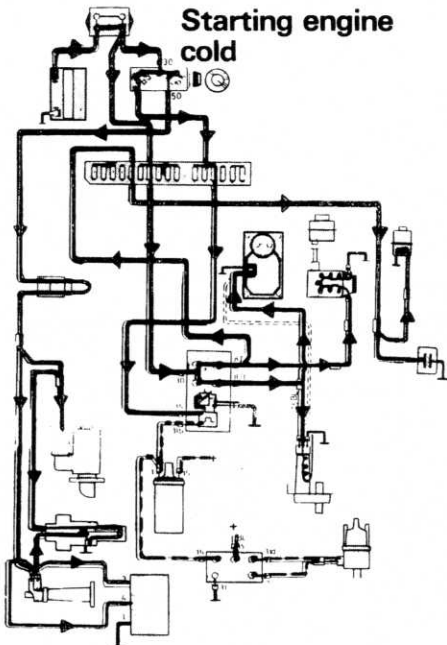

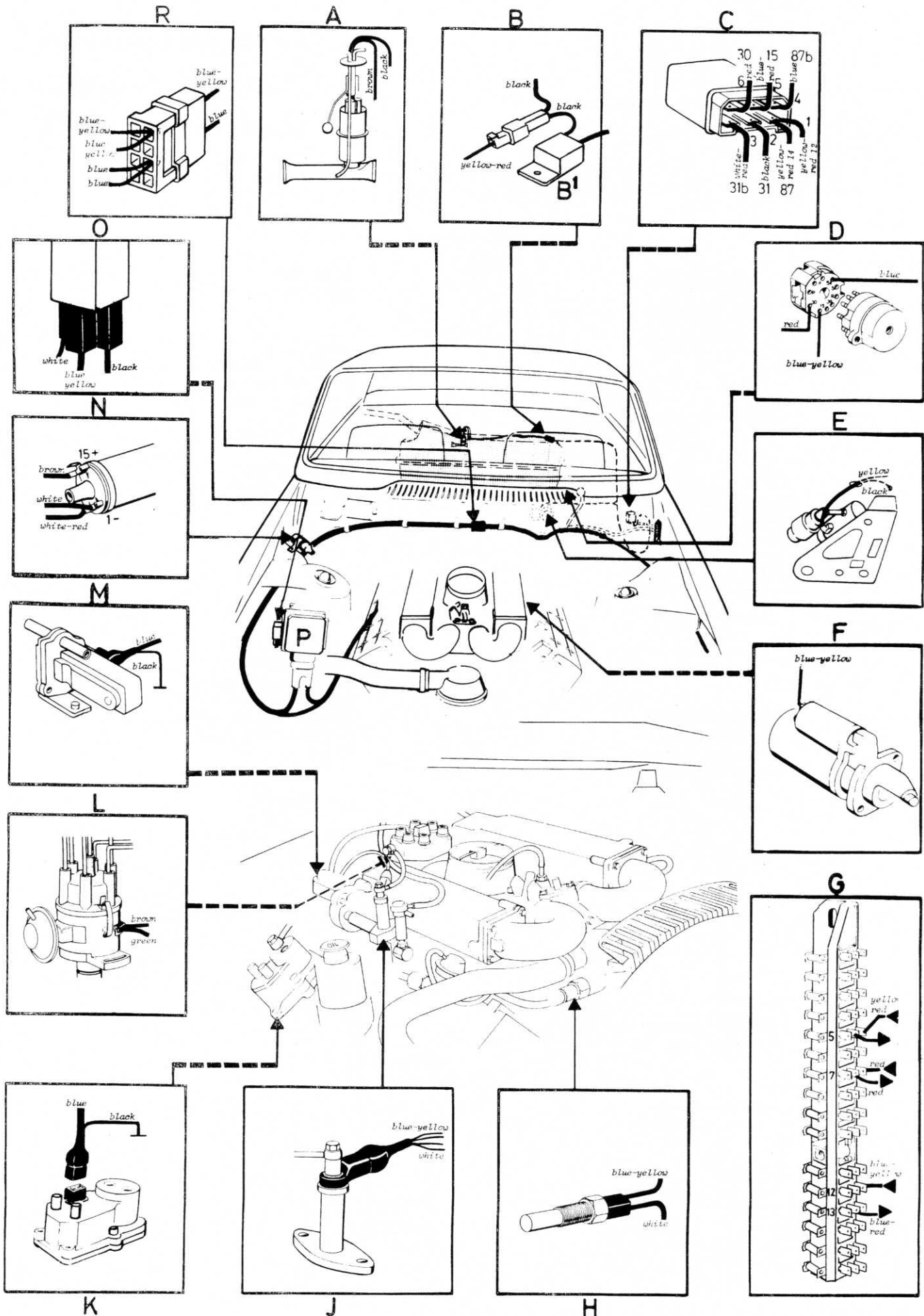

Oxygen sensor feedback system (Lambda-sond) B21F

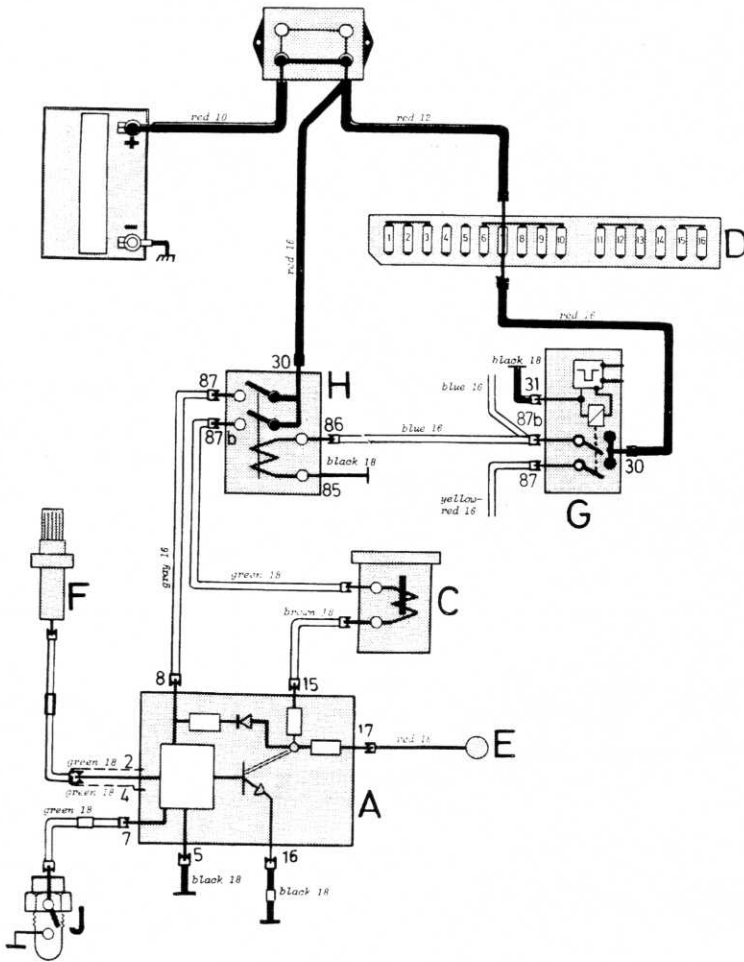

Fuse No. 7:
Fuel pump (main pump)

- Legend:**
- A Electronic module
 - B Ground points
 - C Frequency valve
 - D Fuse box
 - E Test instrument pick-up point
 - F Oxygen sensor
 - G Electronic pump relay
 - H System relay

Warm engine.
System operates on duty cycle, regulating air/fuel mixture.

Cold engine.
Circuit through thermal switch is closed = system operates on fixed cycle and provides richer air/fuel mixture.

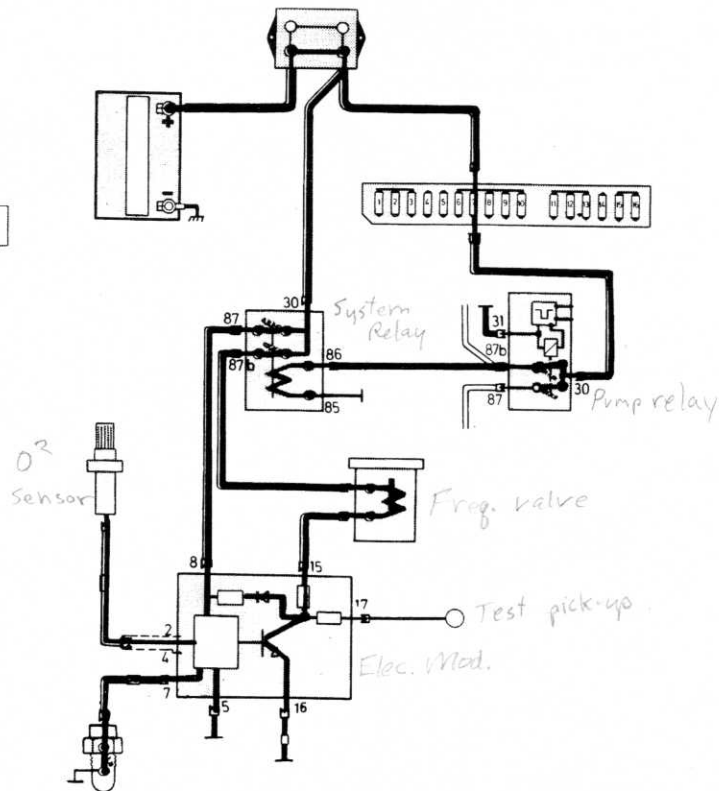
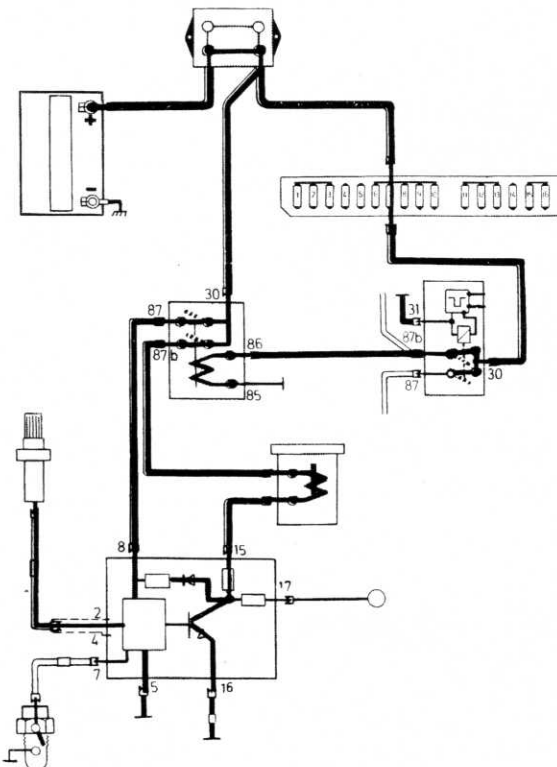

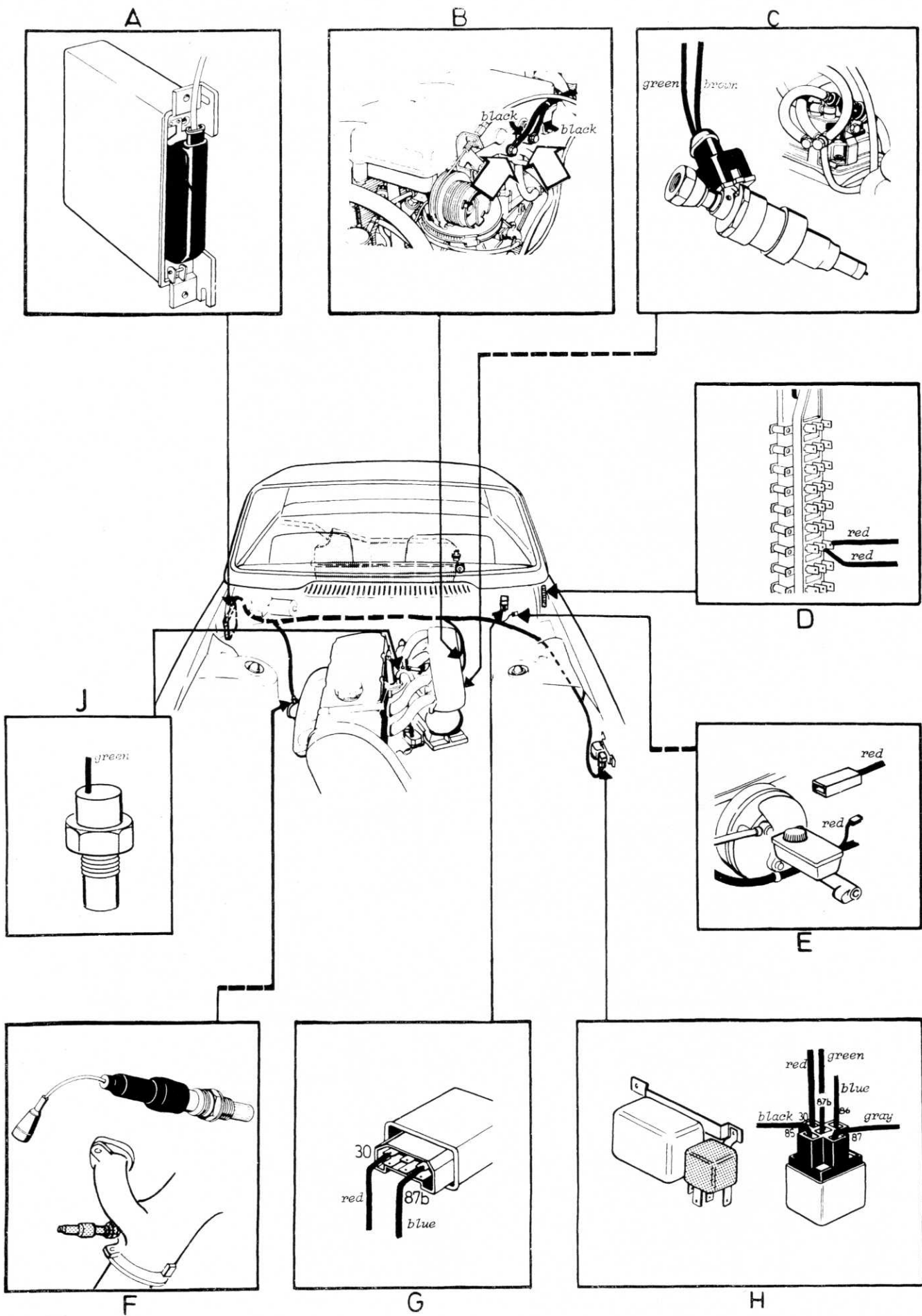

Oxygen sensor feedback system (Lambda-sond) B21F-Turbo

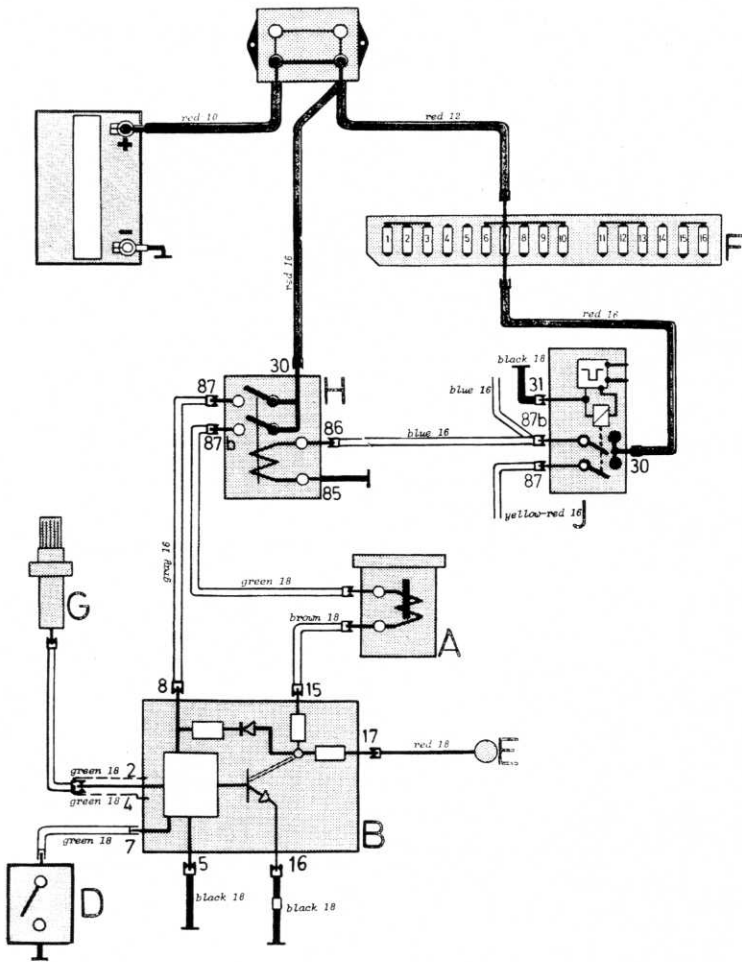

Fuse No. 7:
Fuel pump (main pump)

Legend:

- A Frequency valve
- B Electronic module
- C Ground points
- D Pressure switch
- E Test instrument pick-up point
- F Fuse box
- G Oxygen sensor
- H System relay
- J Electronic pump relay

Acceleration.

Increasing compressor discharge pressure causes pressure switch to ground terminal 7 of Electronic module. This will cause Lambda system to operate on special fixed cycle and provide enrichment.

Normal driving.

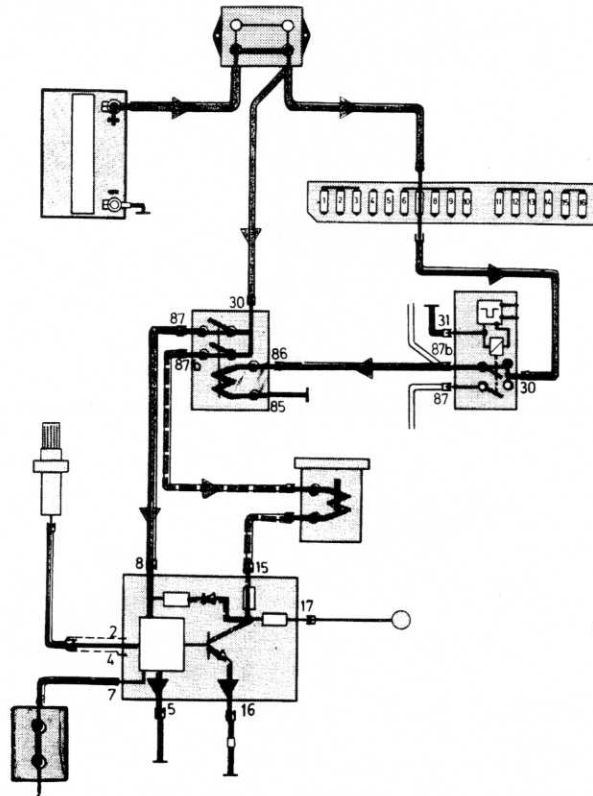
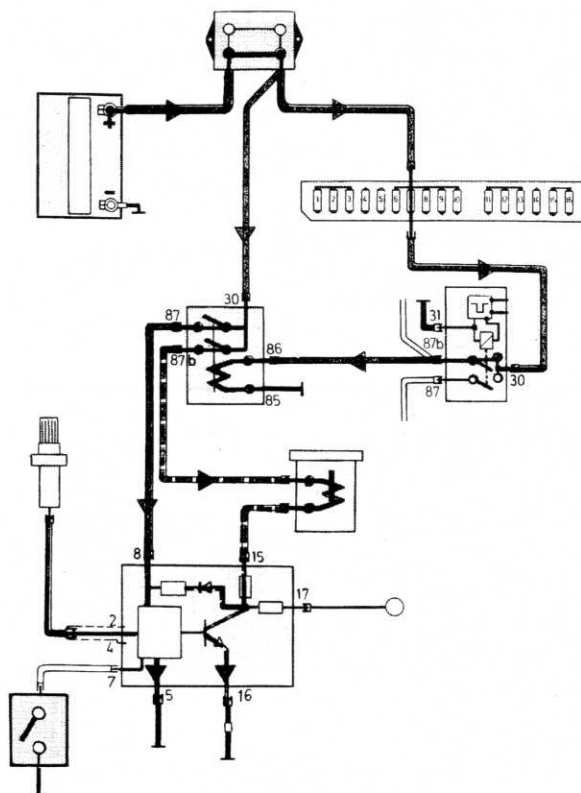

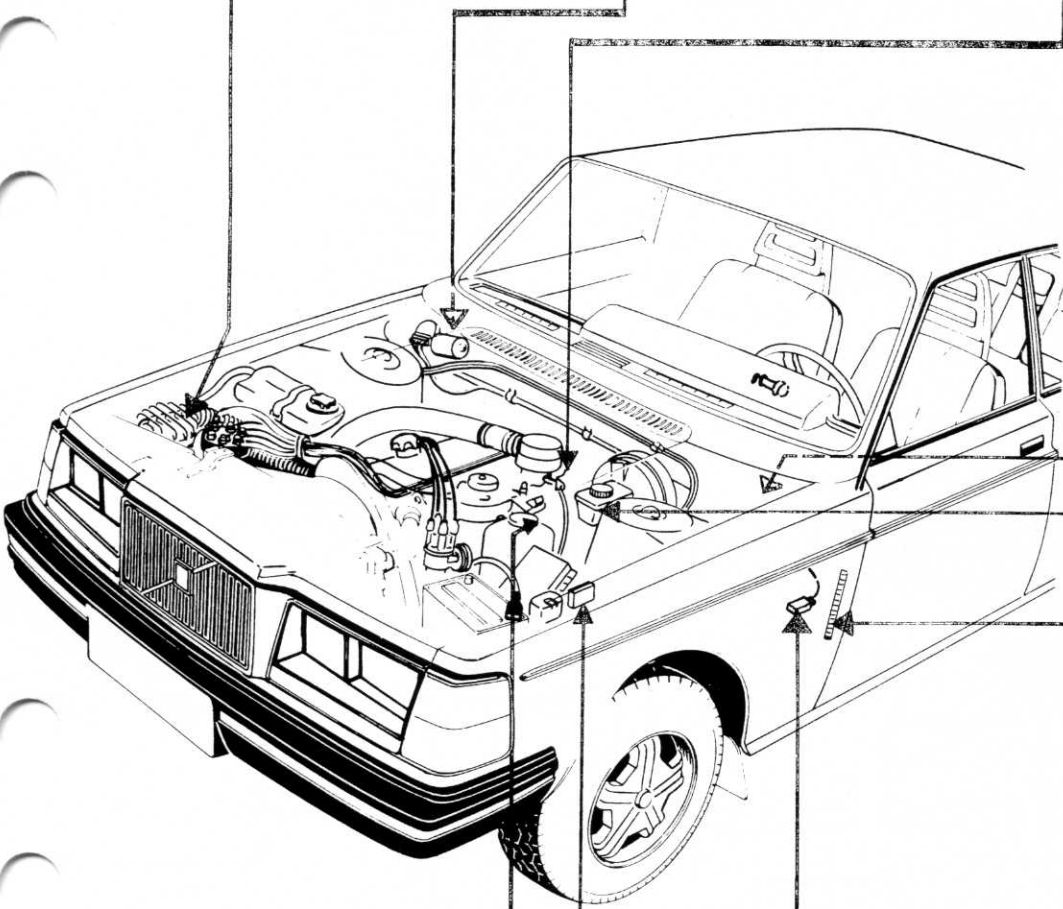
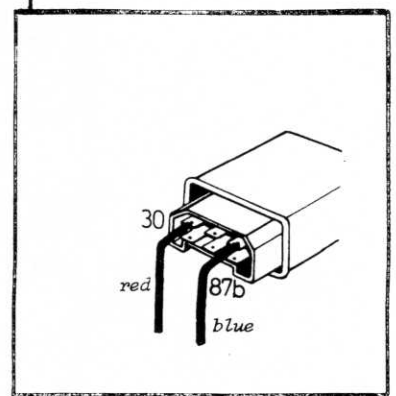
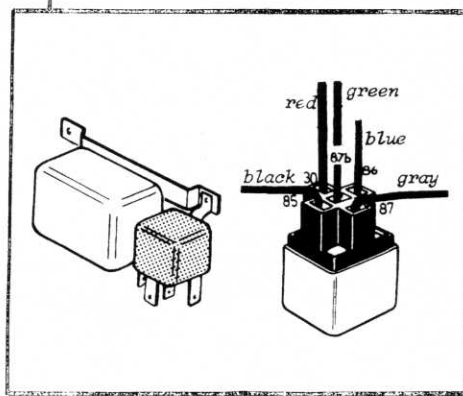
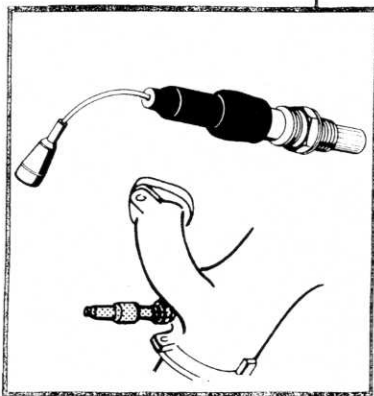
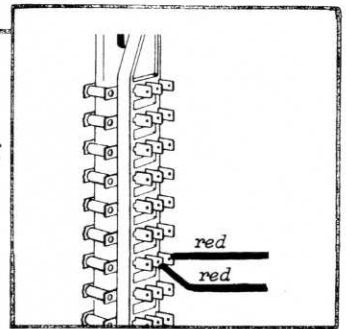
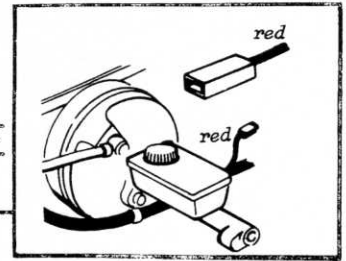
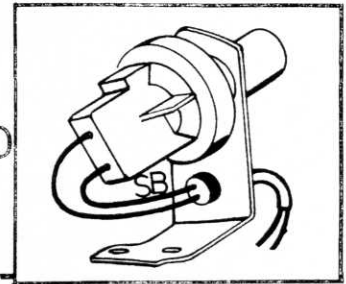
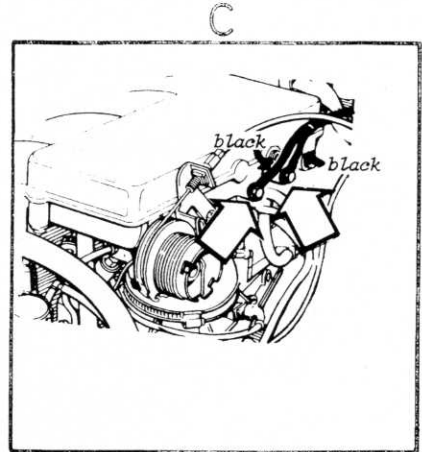
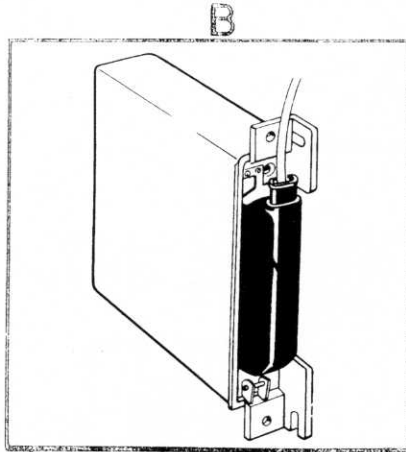
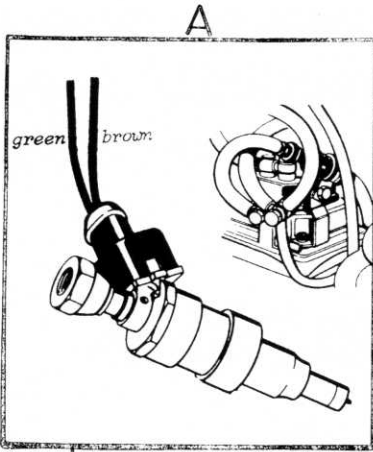

Oxygen sensor feedback system (Lambda-sond) B28F

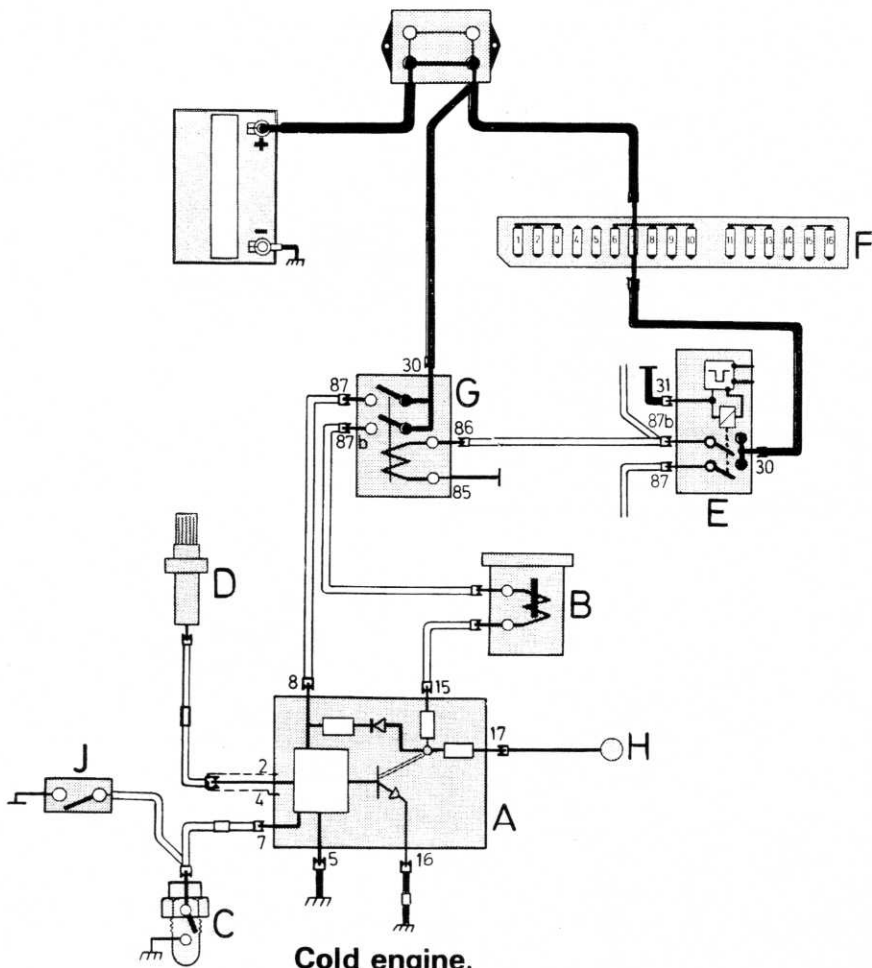

Fuse No. 7:
Fuel pump (main pump)

- Legend:**
- A Electronic module
 - B Frequency valve
 - C Thermal switch
 - D Oxygen sensor
 - E Electronic pump relay
 - F Fuse box
 - G System relay
 - H Test instrument pick-up point
 - J Micro switch (for enrichment at maximum acceleration)
 - K Ground points

Cold engine.
Circuit through thermal switch is closed = system operates on fixed cycle and provides richer air/fuel mixture.

Maximum acceleration.
Circuit through micro switch is closed = system operates on fixed cycle and provides richer air/fuel mixture.

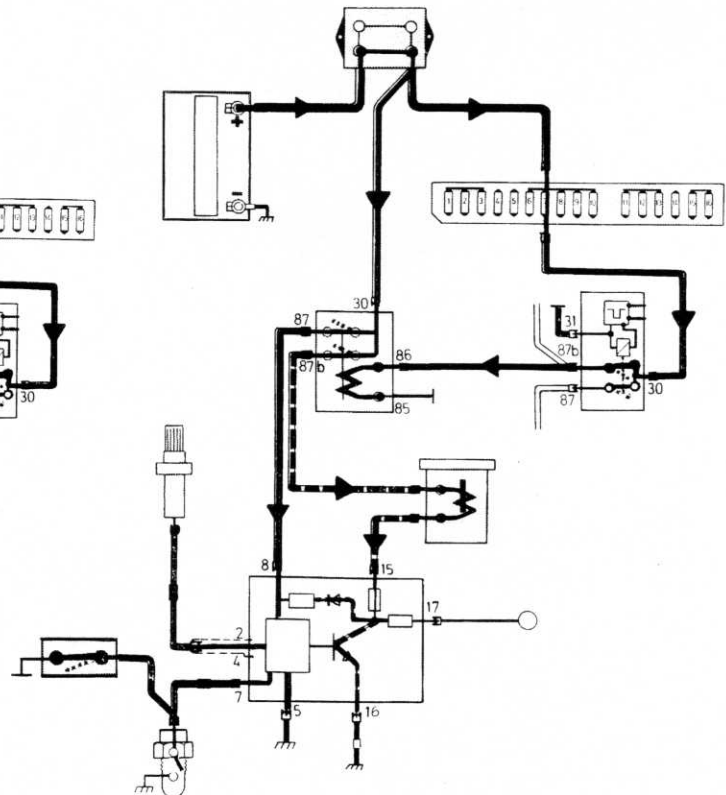
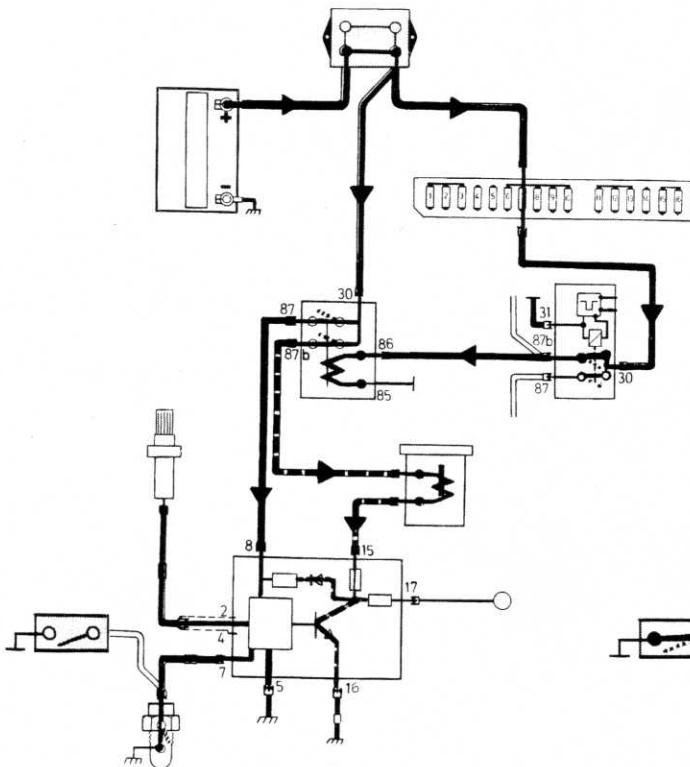

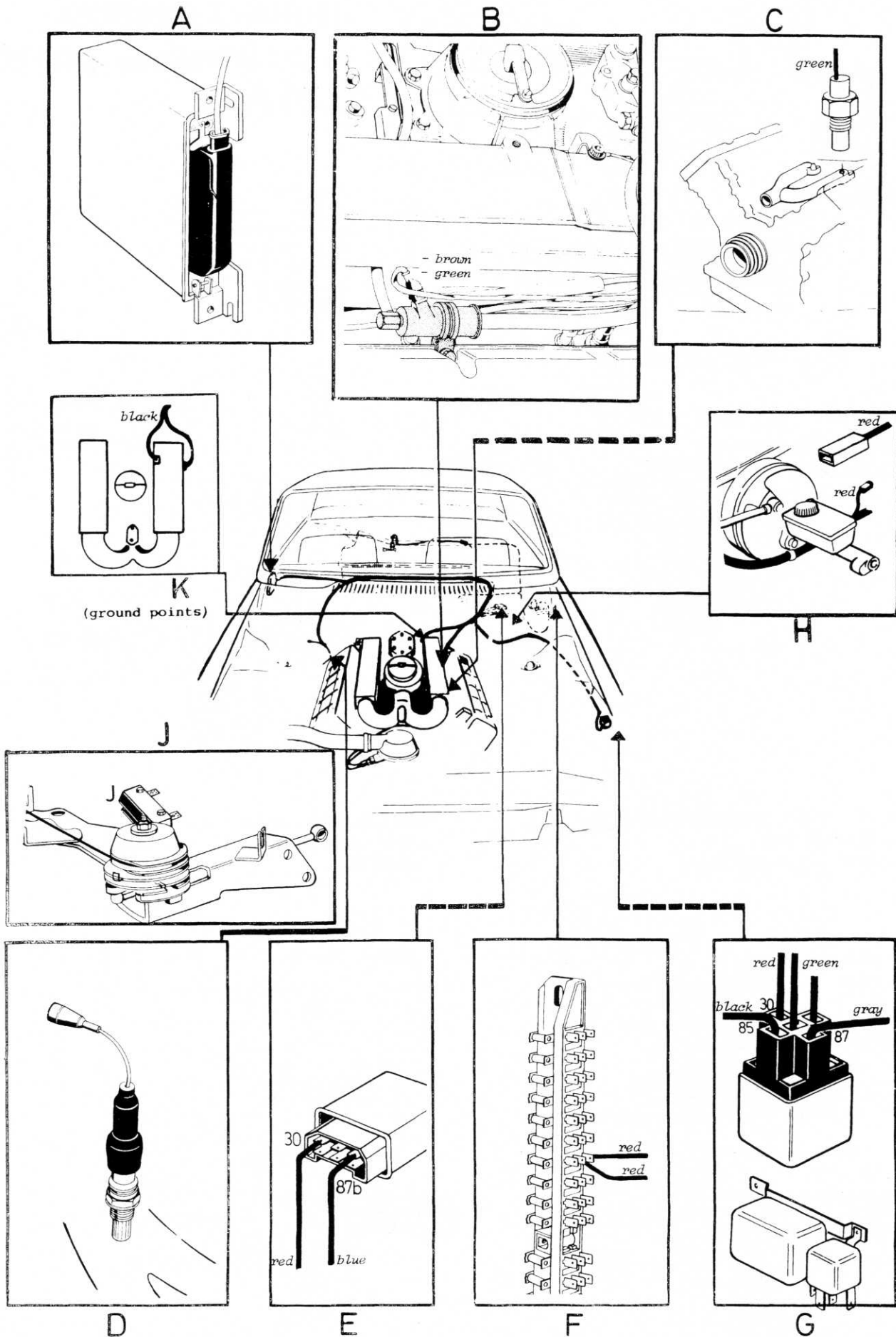

Ignition system with breaker points, B21A

Legend:

- A Ignition coil
- B Ignition switch
- C Distributor
- D Starter motor
- E Fuse box
- F Ballast resistor

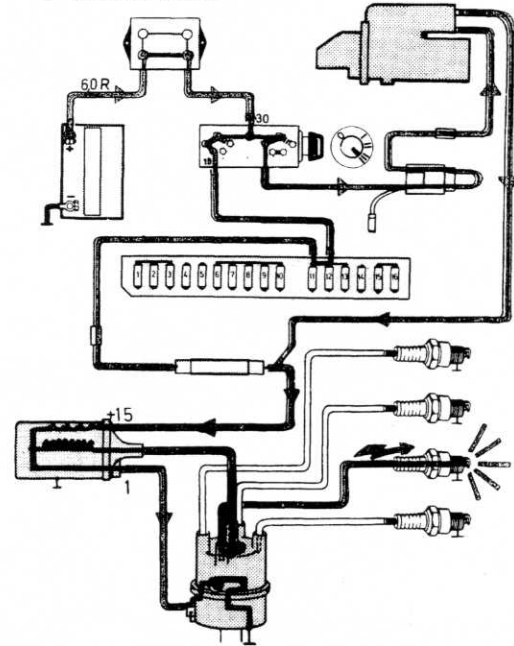
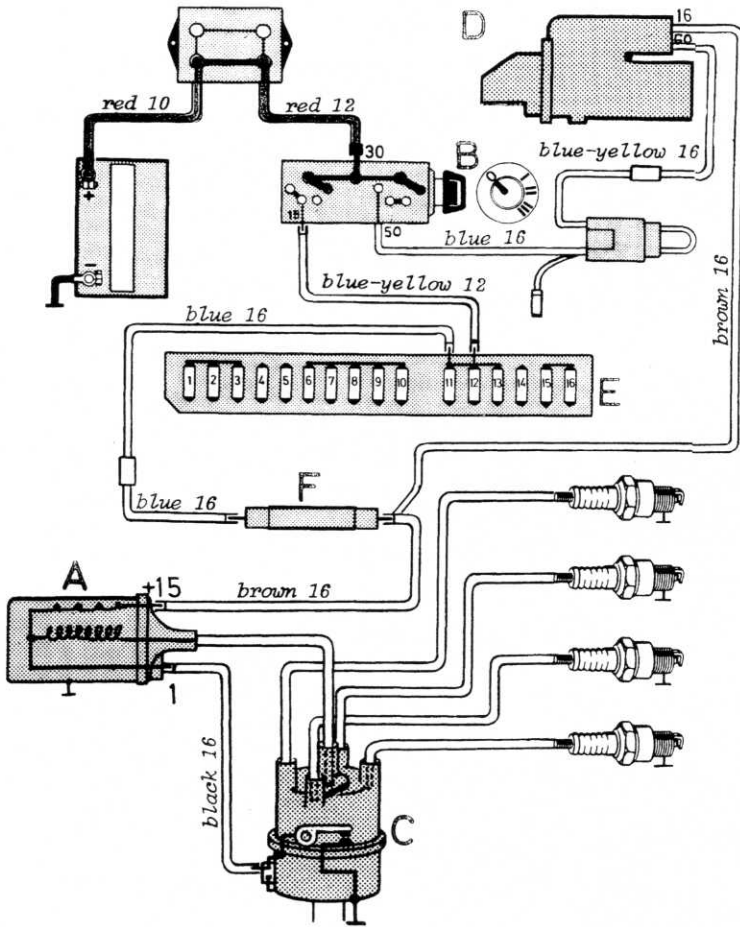

Current flows through breaker points
and ignition coil.
Ignition coil is energized.

Breaker points open, ignition coil
discharges (sparks) through secondary
winding.

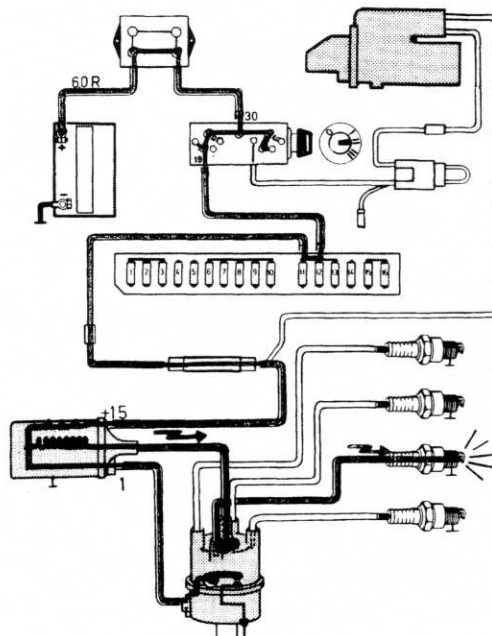
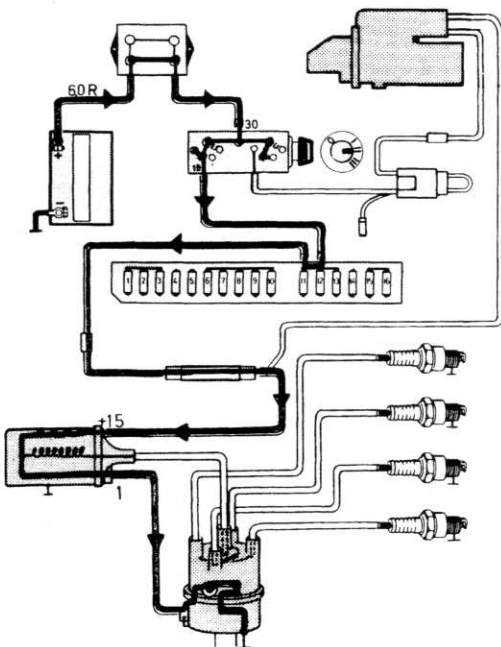

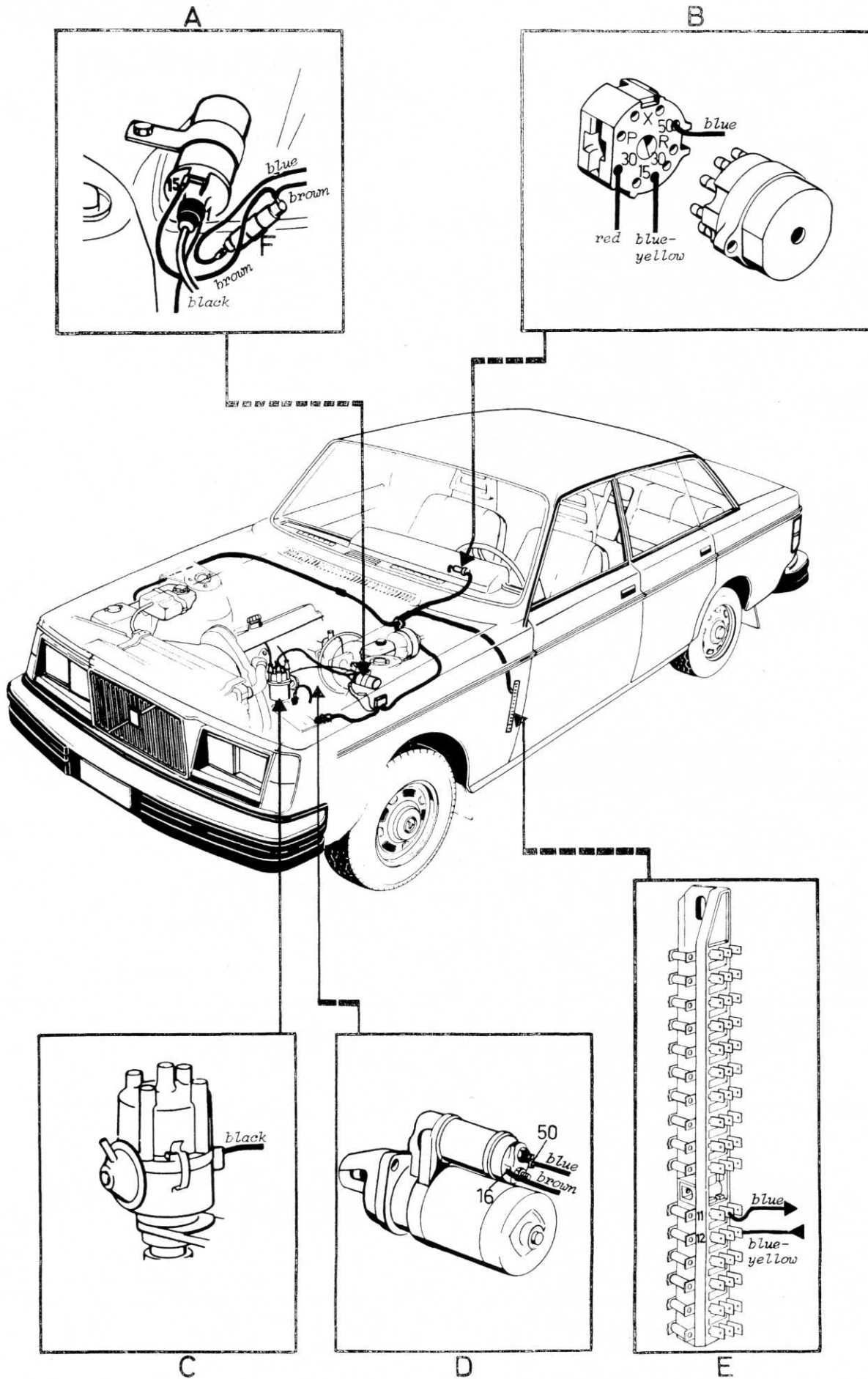

Breakerless electronic ignition system B21F and B21F-Turbo B23E/Canada

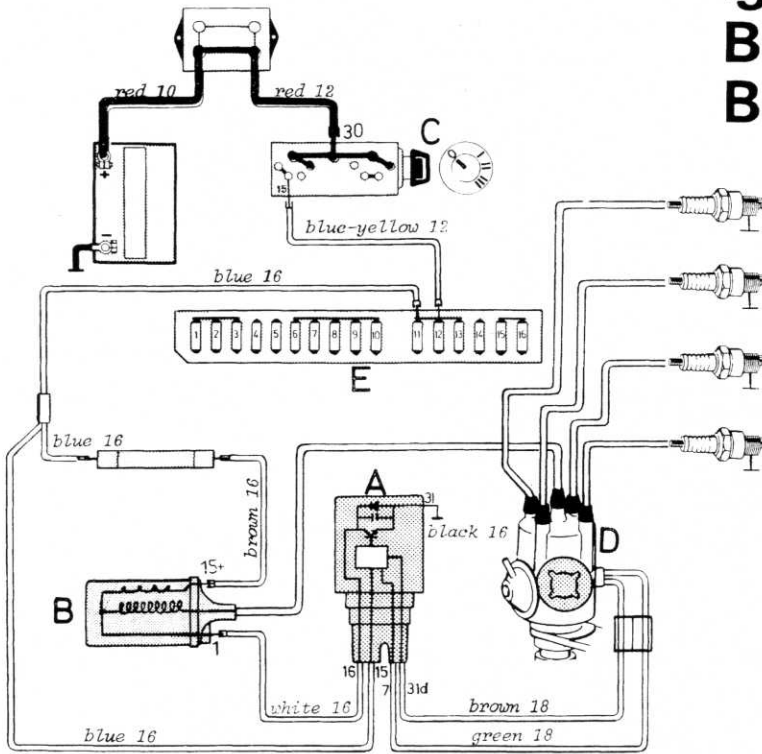

Legend:

- A Ignition electronic module
- B Ignition coil with ballast resistor
- C Ignition switch
- D Distributor w. impulse sender
- E Fuse box

Current flows through electronic module, ignition coil primary winding is energized.

Electronic module interrupts current flow, ignition coil discharges (sparks) through secondary winding.

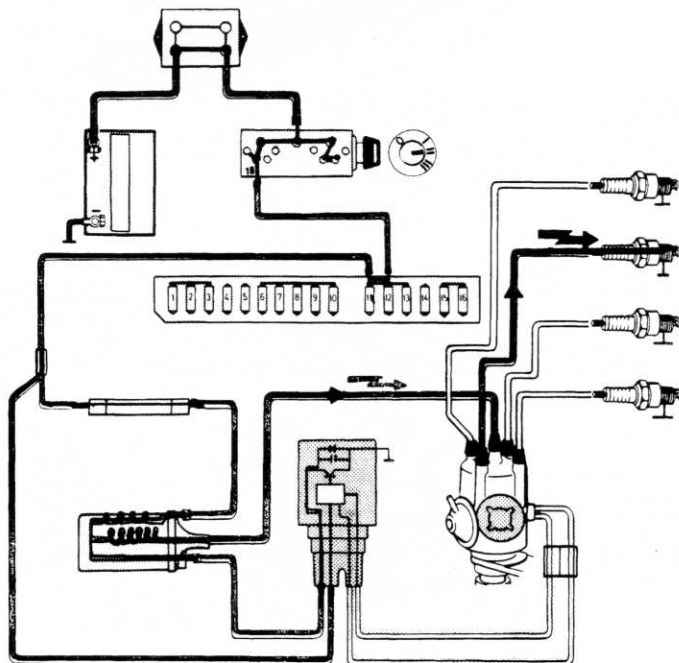
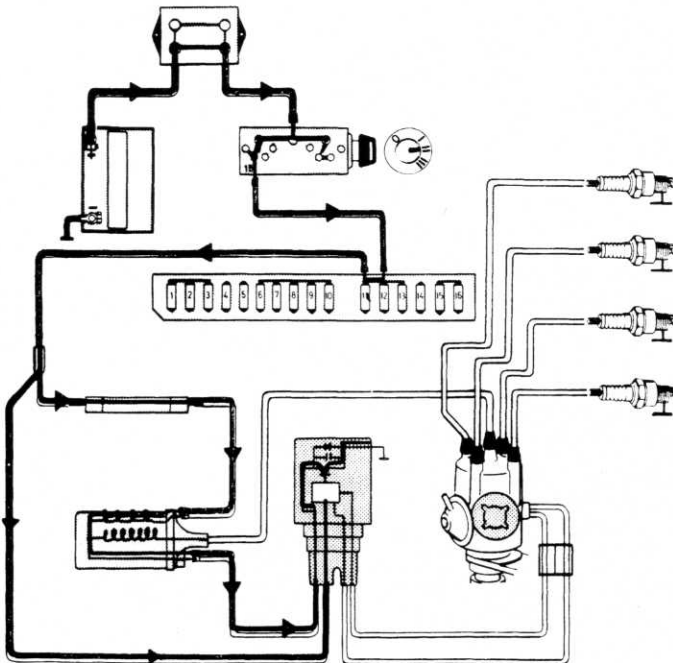

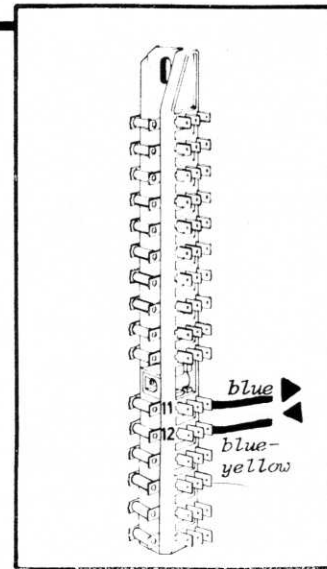
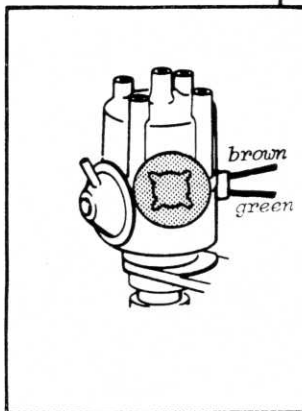
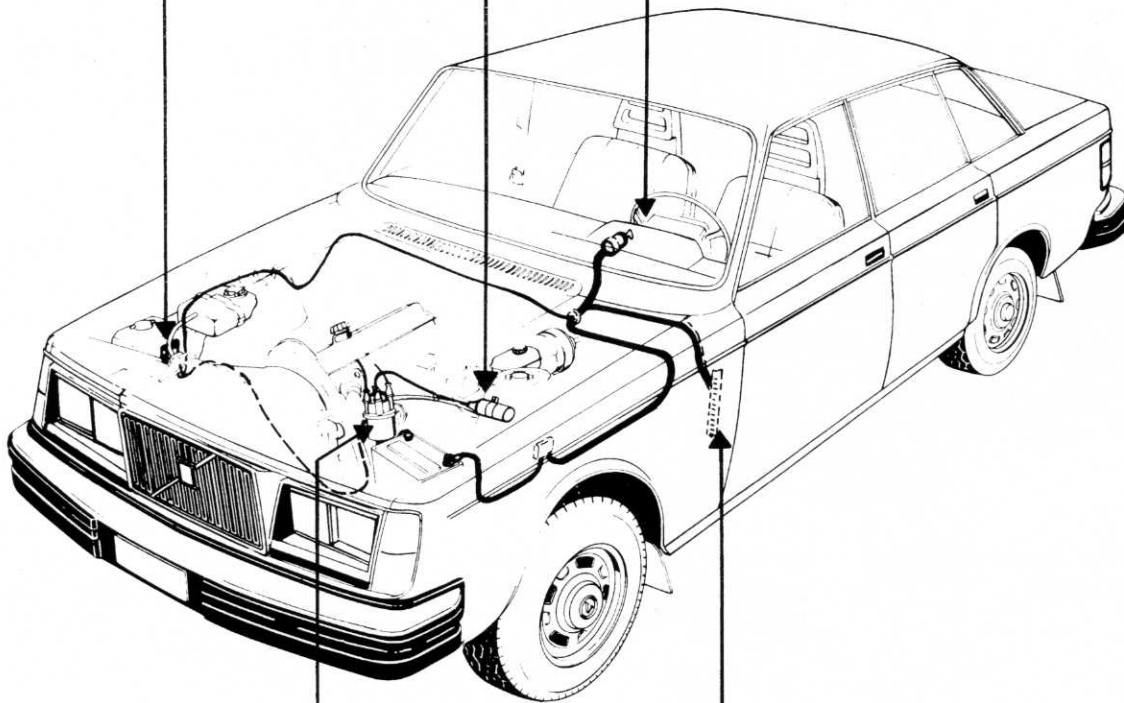
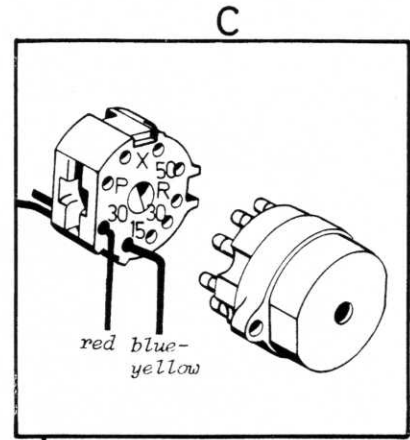
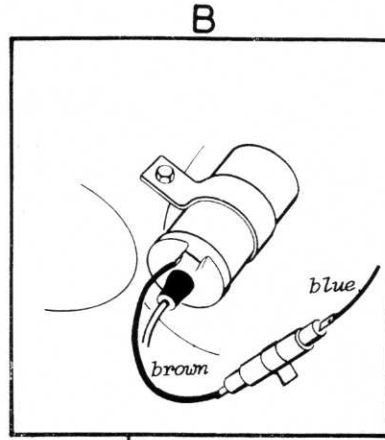
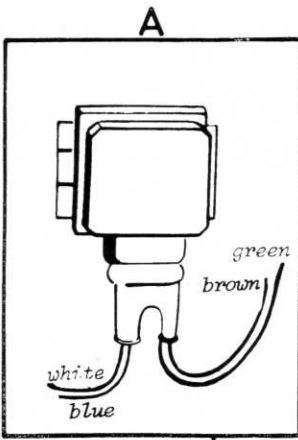

Computer controlled ignition system B21F-MPG

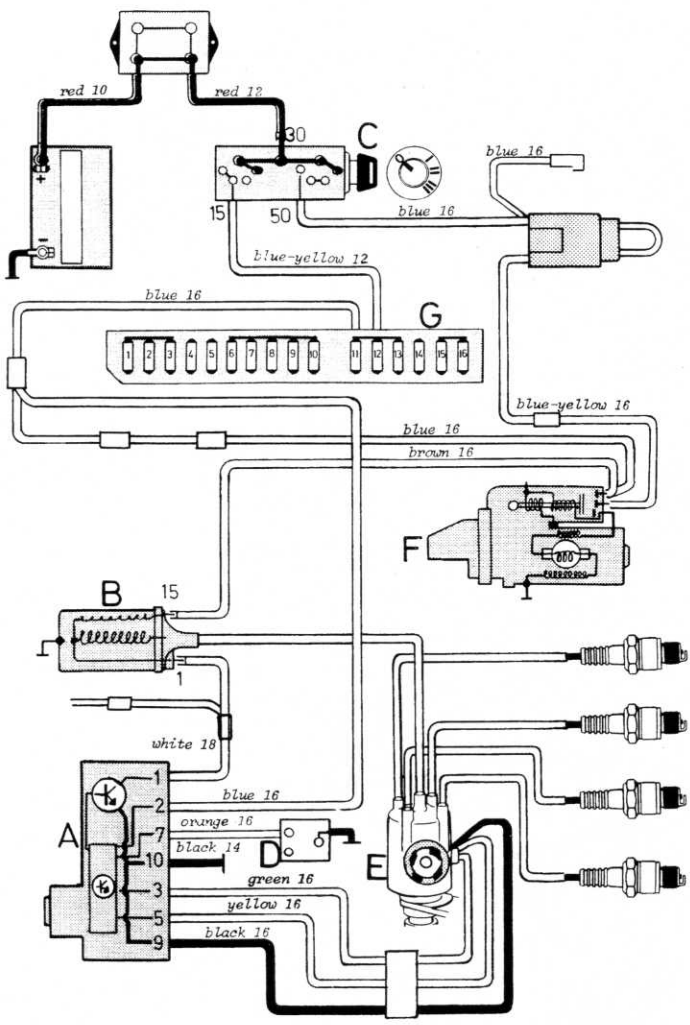

- Legend:**
- A Electronic Control Unit
 - B Ignition coil
 - C Ignition switch
 - D Micro switch
 - E Distributor
 - F Starter motor
 - G Fuse box

**Ignition ON , engine running,
ignition coil being
energized.**

**Ignition ON , engine running,
ignition coil discharges
(sparks).**

**Ignition ON , engine stalled.
Micro switch grounds
circuit through Electronic
Control Unit.**

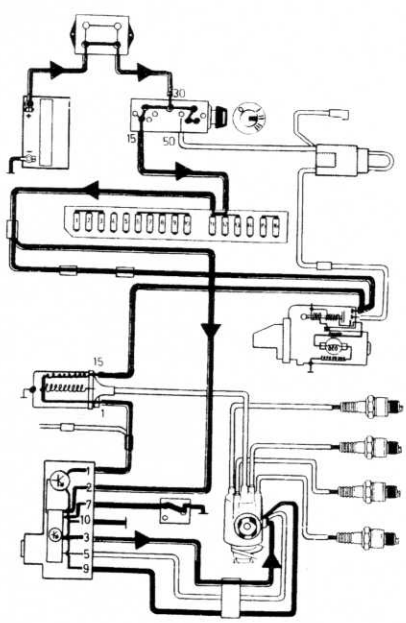
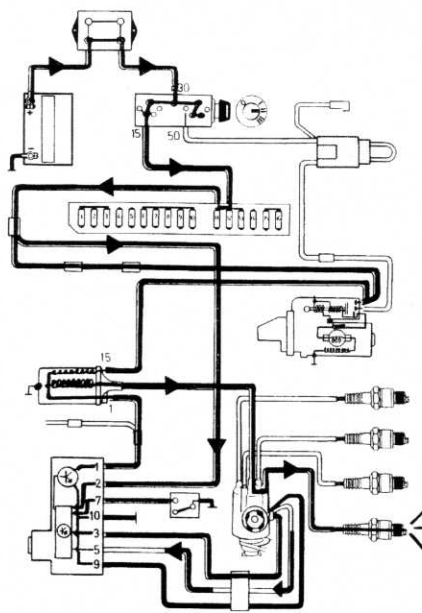
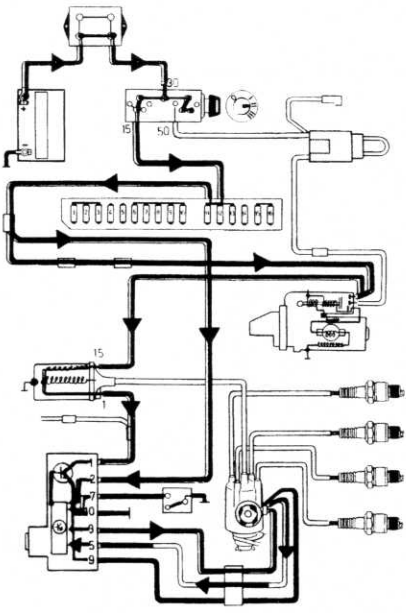

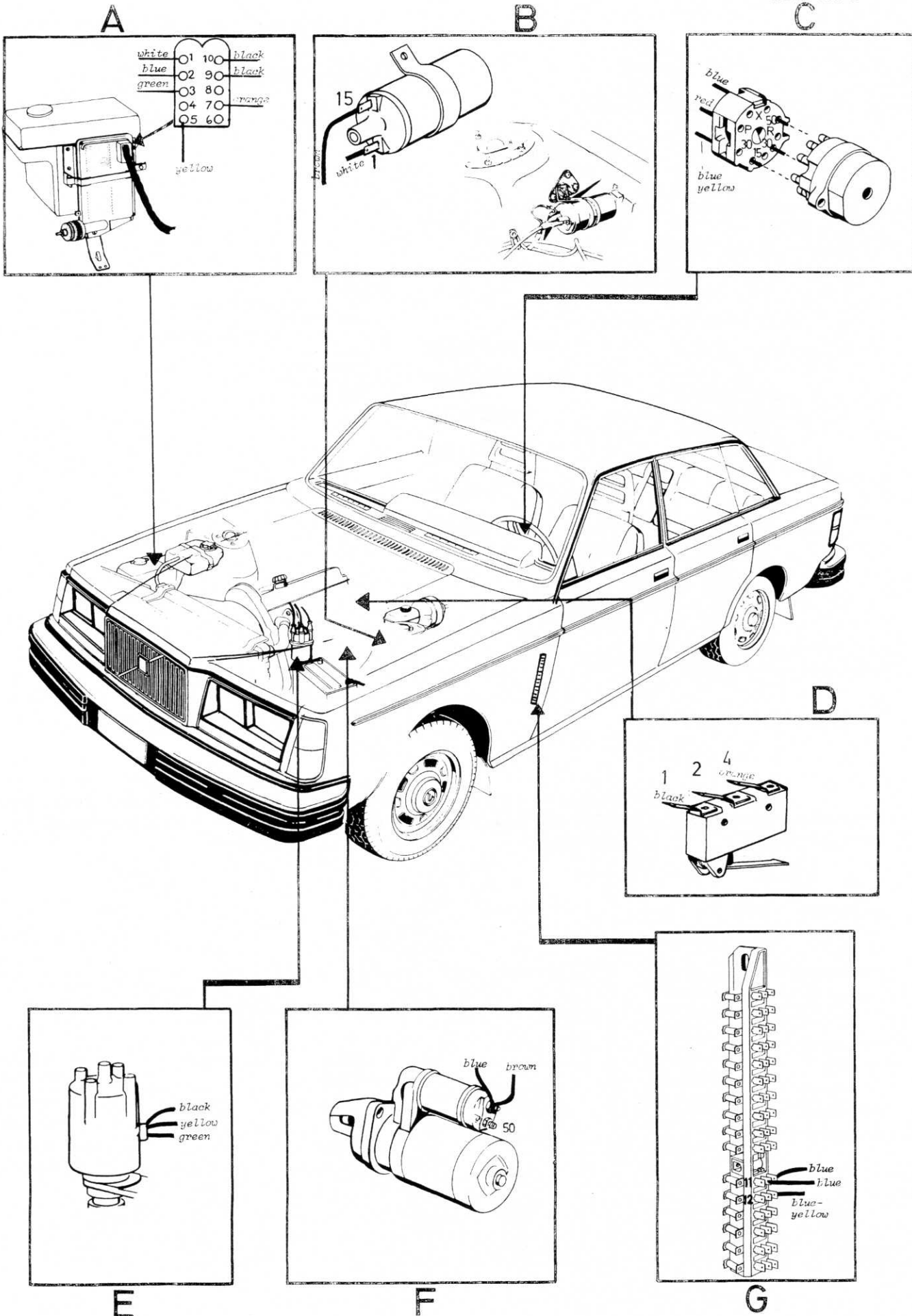

Breakerless electronic ignition system B28F

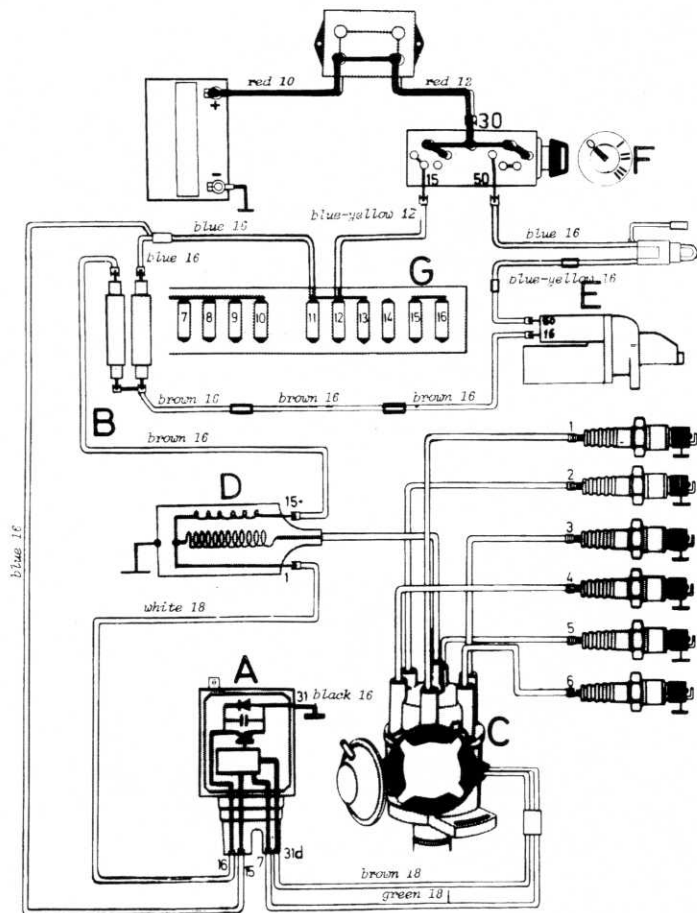

- Legend:**
- A Ignition electronic module
 - B Ballast resistor
 - C Distributor w. impulse sender
 - D Ignition coil
 - E Starter motor
 - F Ignition switch
 - G Fuse box

Current flow while starter motor is engaged.

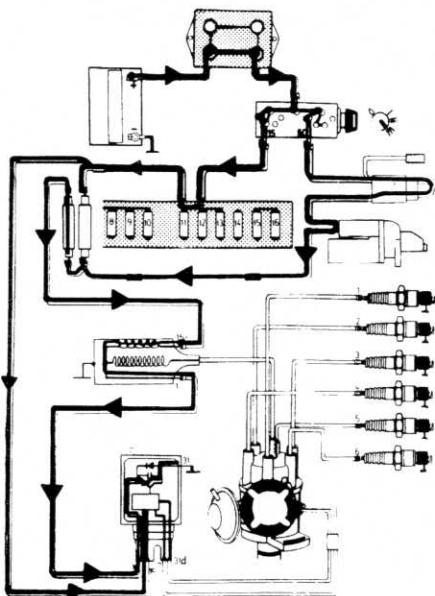

Current flows through electronic module, ignition coil primary winding is energized.

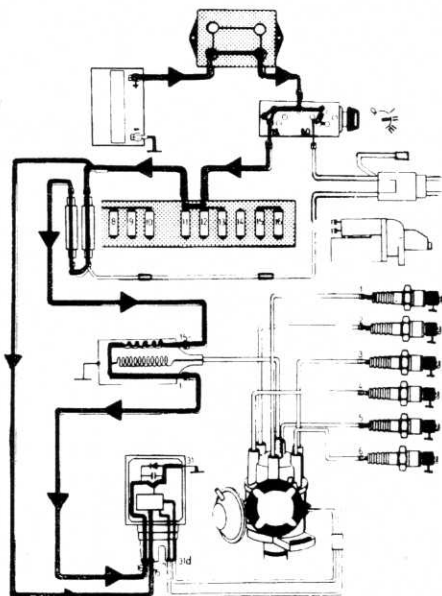

Electronic module interrupts current flow, ignition discharges (sparks) through secondary winding.

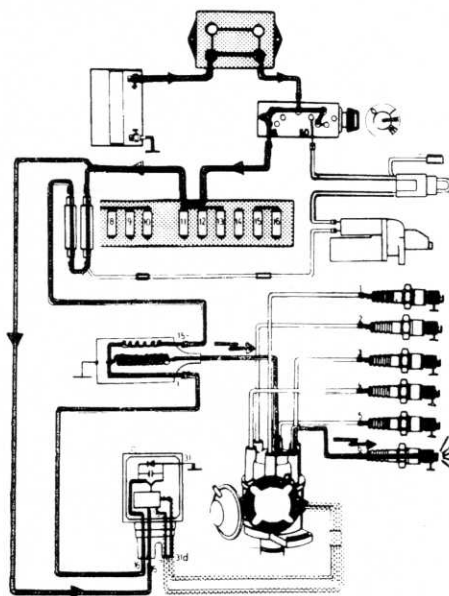

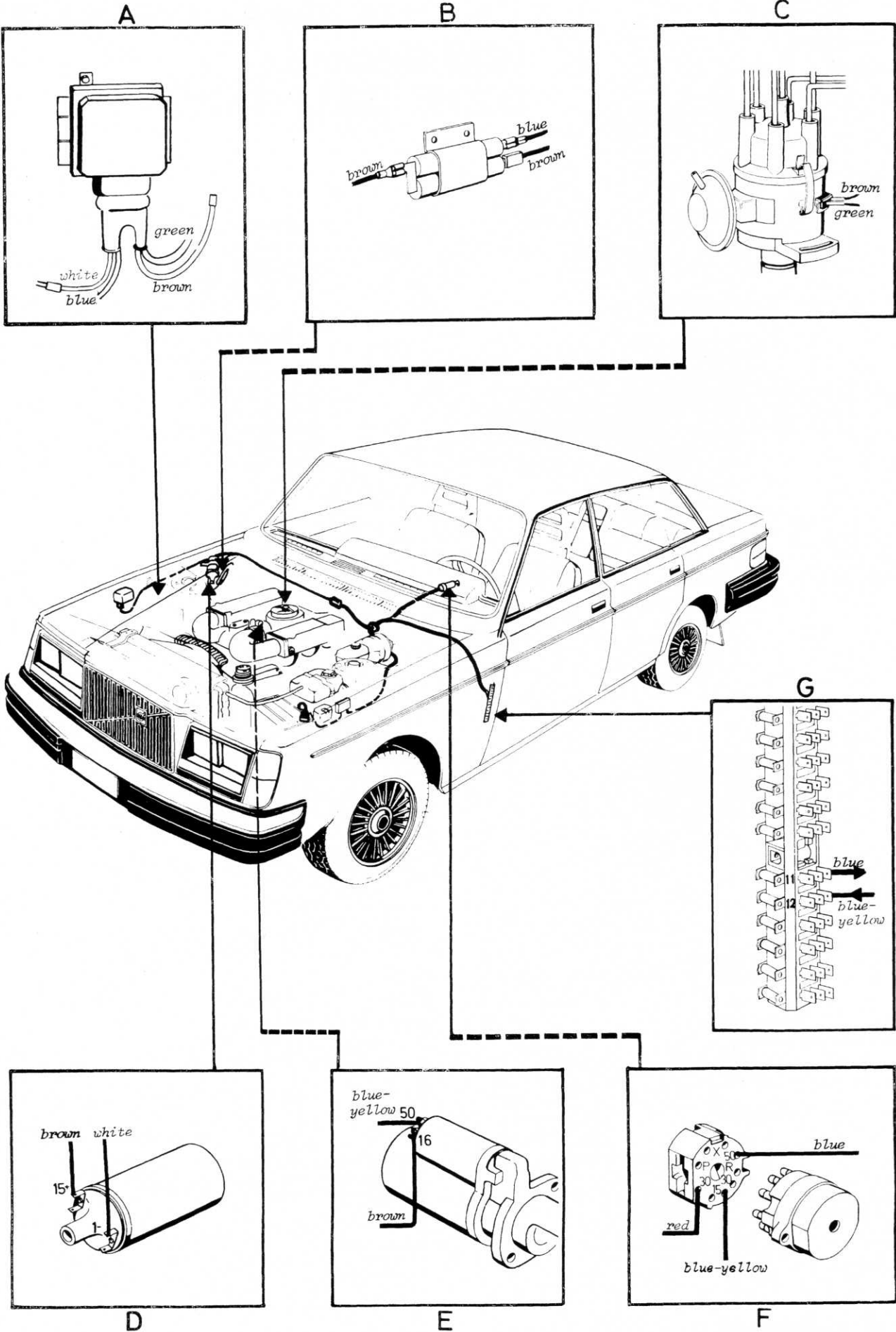

Dad's Car

Constant Idle Speed System (CIS System) B21F, B21F-MPG

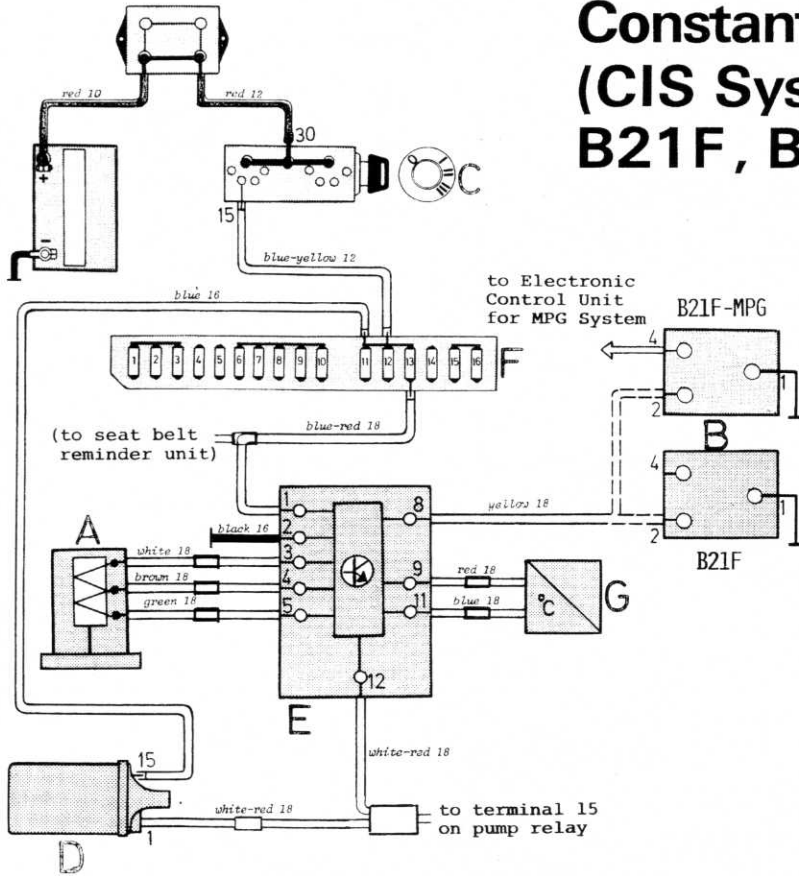

Fuse No. 13:
Instruments
Turn signals
Seat belt warning
CIS System

Legend:
A Air control valve
B Throttle switch
C Ignition switch
D Ignition coil
E Electronic control unit
F Fuse box
G Coolant temperature sensor

Idle speed.

Ground circuit through throttle switch is interrupted. Electronic Control unit controls Air Control Valve to set correct idle speed.

Above idle speed.

Ground circuit through throttle switch is closed. Electronic Control Unit controls Air Control Valve to set high air flow (and avoid engine stalls).

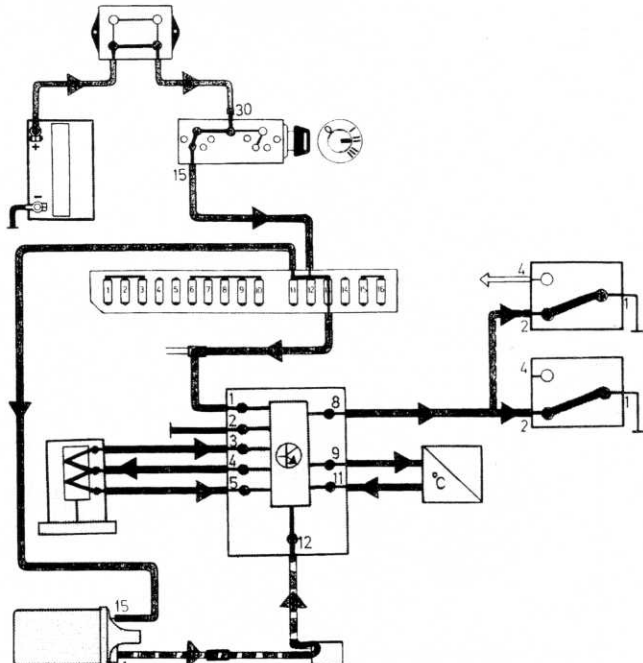
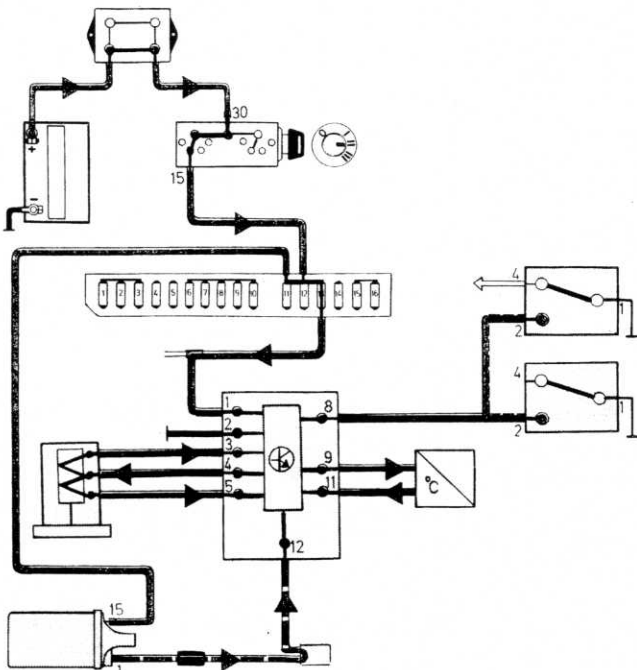

Constant Idle Speed System (CIS System) B21F-Turbo

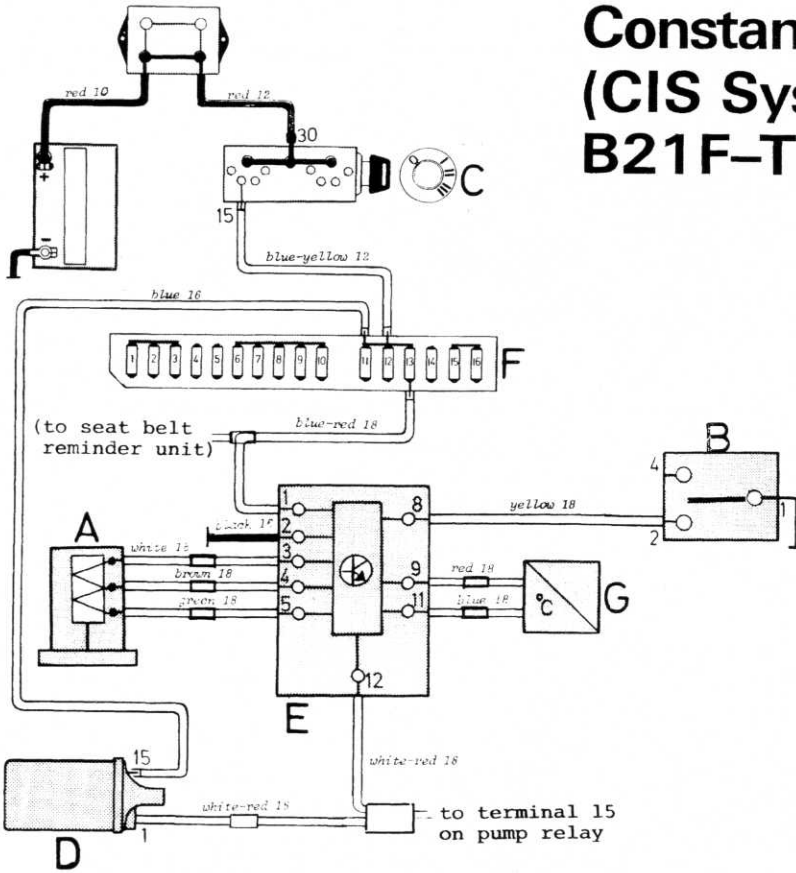

Fuse No. 13:
Instruments
Turn signals
Seat belt warning
CIS System

Legend:
A Air control valve
B Throttle switch
C Ignition switch
D Ignition coil
E Electronic control unit
F Fuse box
G Coolant temperature sensor

Idle speed.

Ground circuit through throttle switch is interrupted. Electronic Control unit controls Air Control Valve to set correct idle speed.

Above idle speed.

Ground circuit through throttle switch is closed. Electronic Control Unit controls Air Control Valve to set high air flow (and avoid engine stalls).

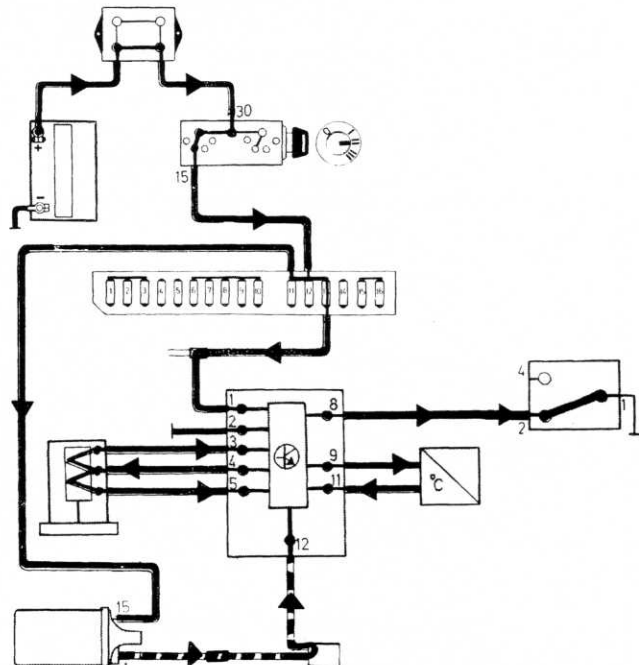
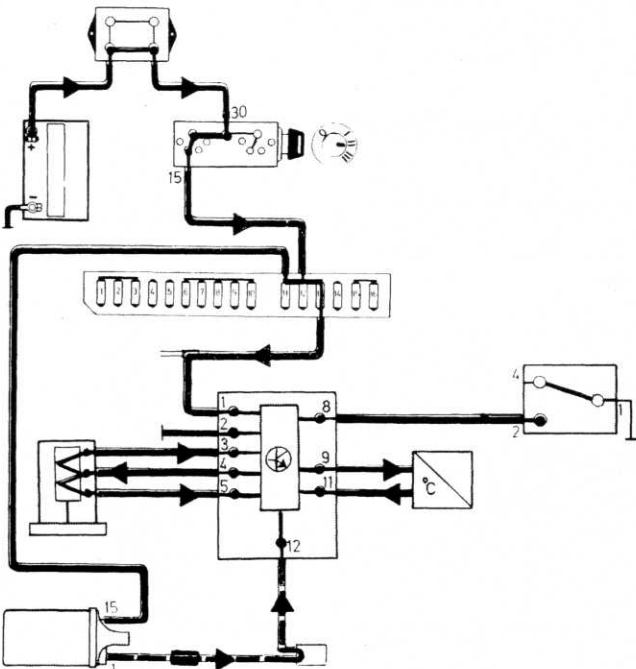

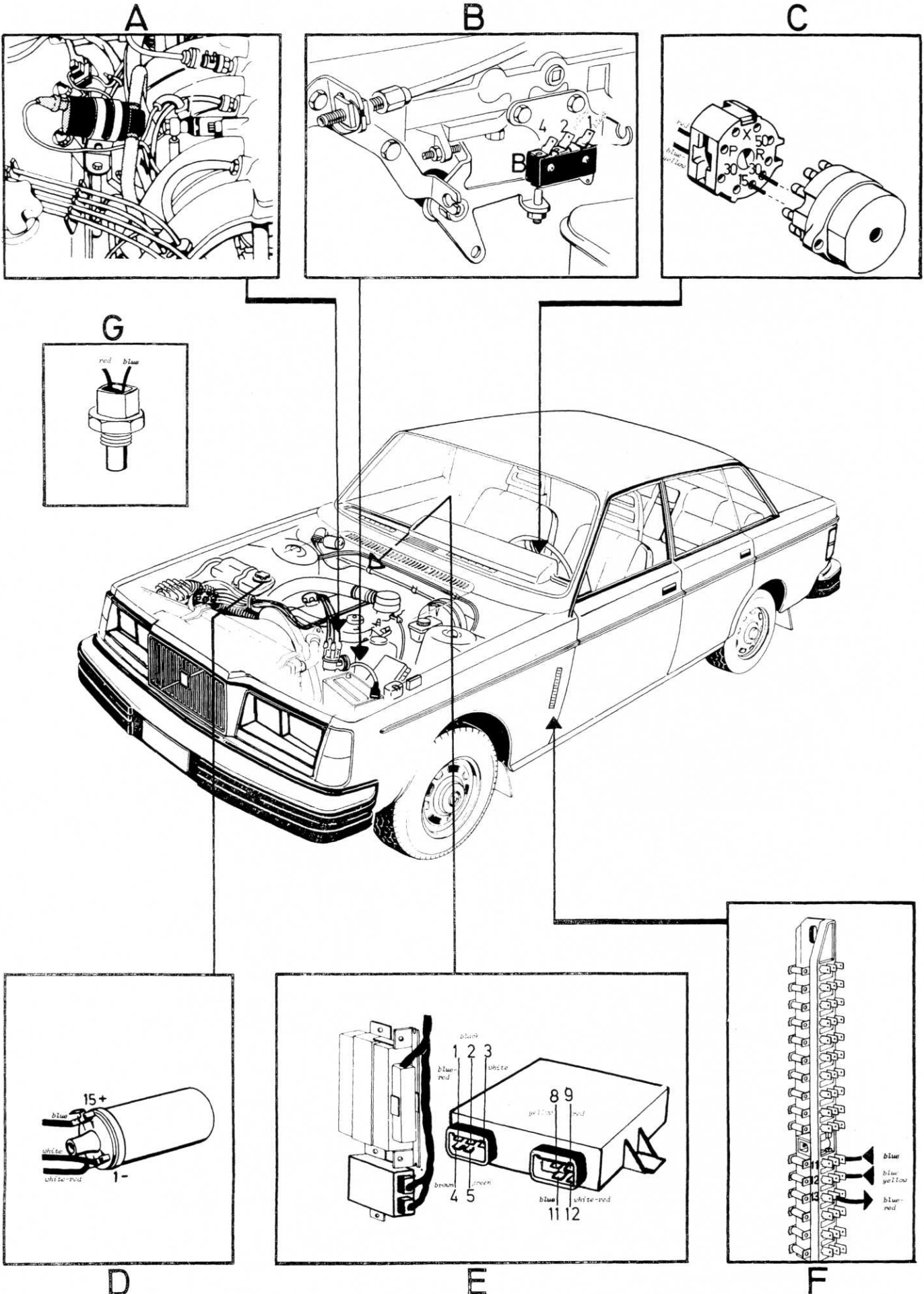

Constant Idle Speed System (CIS System) B28F

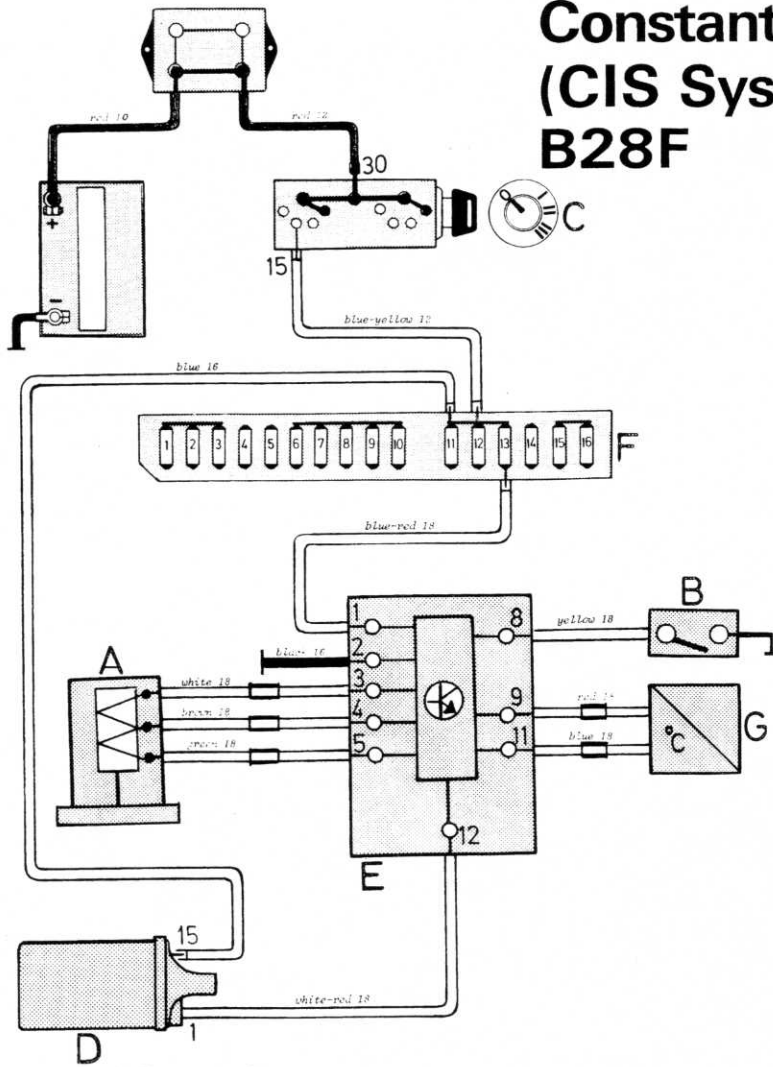

Fuse No. 13:

- Instruments
- Turn signals
- Seat belt warning
- CIS System

Legend:

- A Air control valve
- B Throttle switch
- C Ignition switch
- D Ignition coil
- E Electronic control unit
- F Fuse box
- G Coolant temperature sensor

Idle speed.

Ground circuit through throttle switch is closed. Electronic Control unit controls Air Control Valve to set correct idle speed.

Above idle speed.

Ground circuit through throttle switch is interrupted. Electronic Control Unit controls Air Control Valve to set high air flow (and avoid engine stalls).

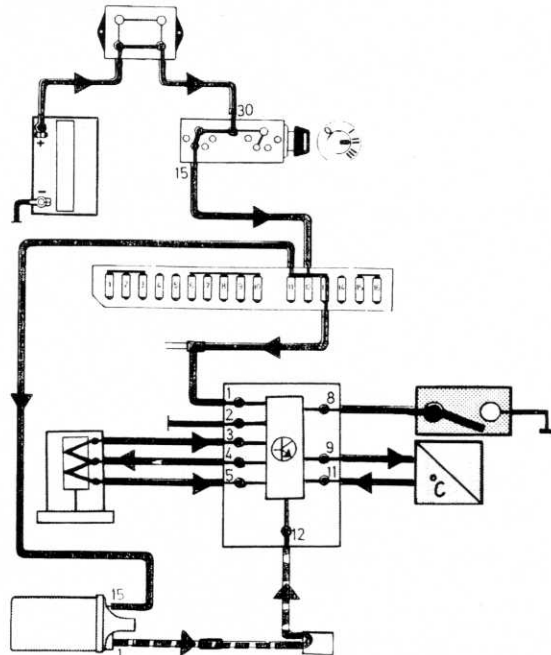
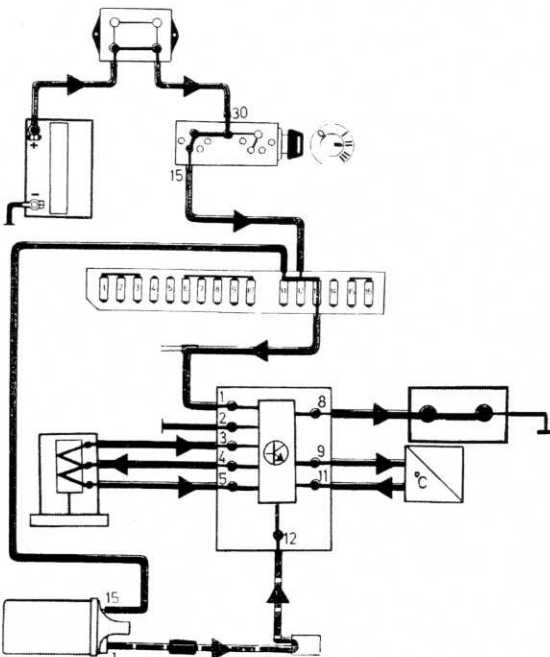

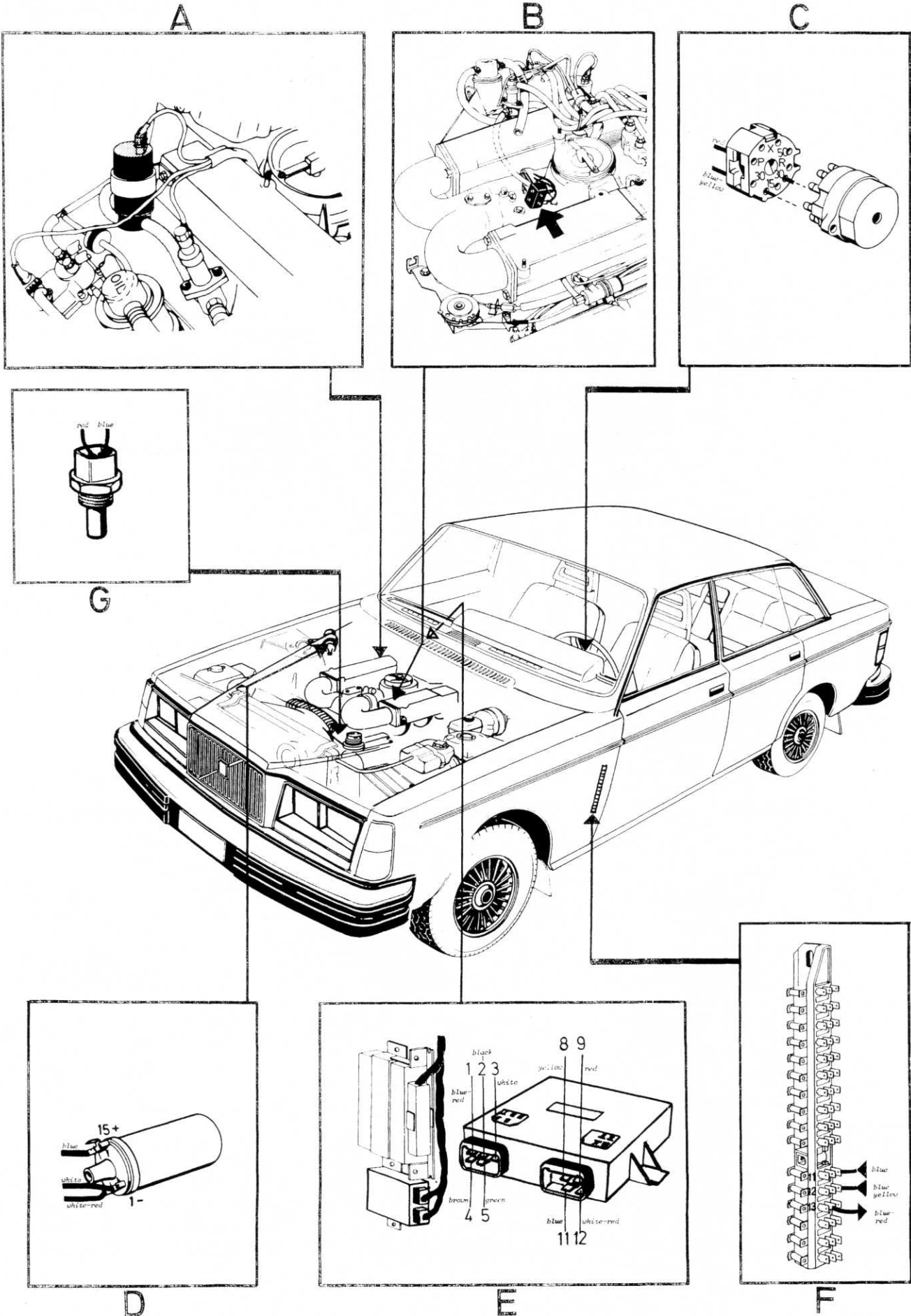

Headlights

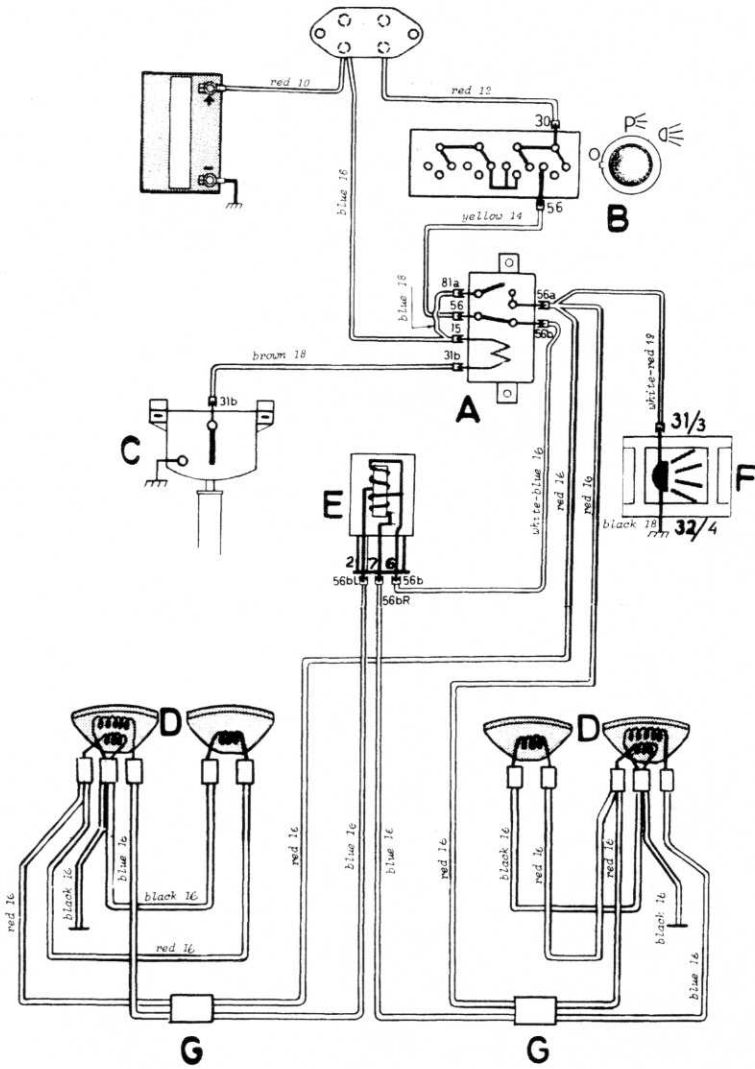

Legend:

- A Upper/lower beam switch relay
- B Light switch
- C Turn signal switch / headlight flasher
- D Headlamps
- F Upper beam indicator light
- G Connectors

Upper beam

Lower beam

Headlight flasher

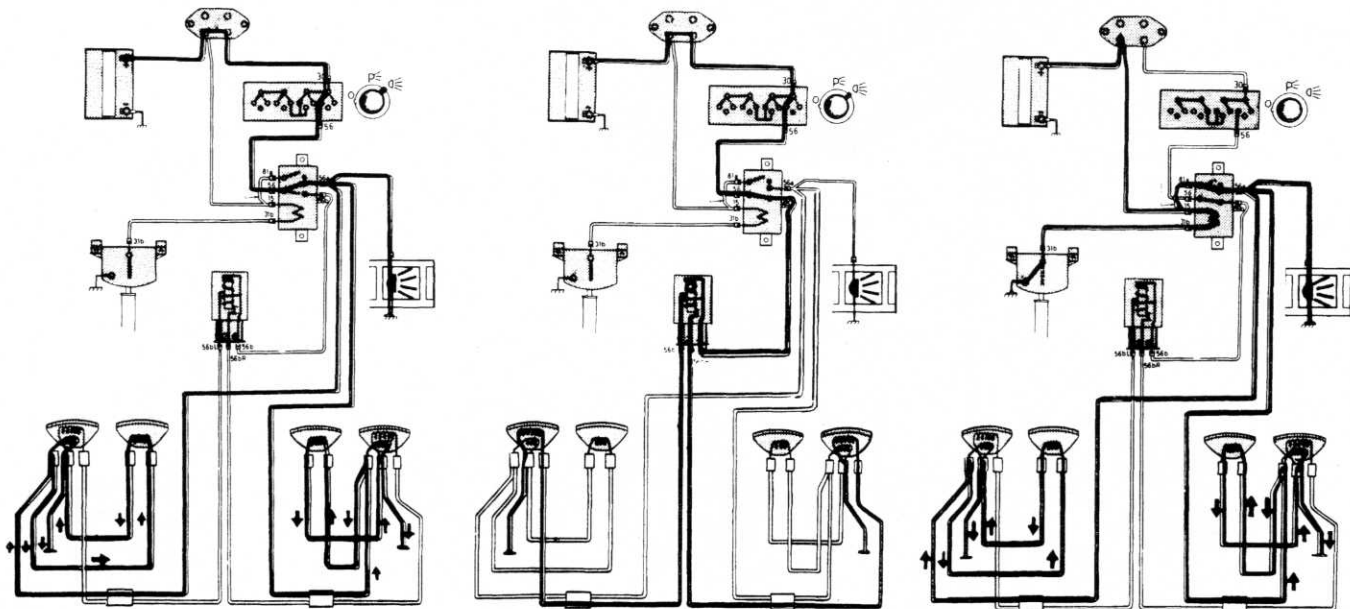

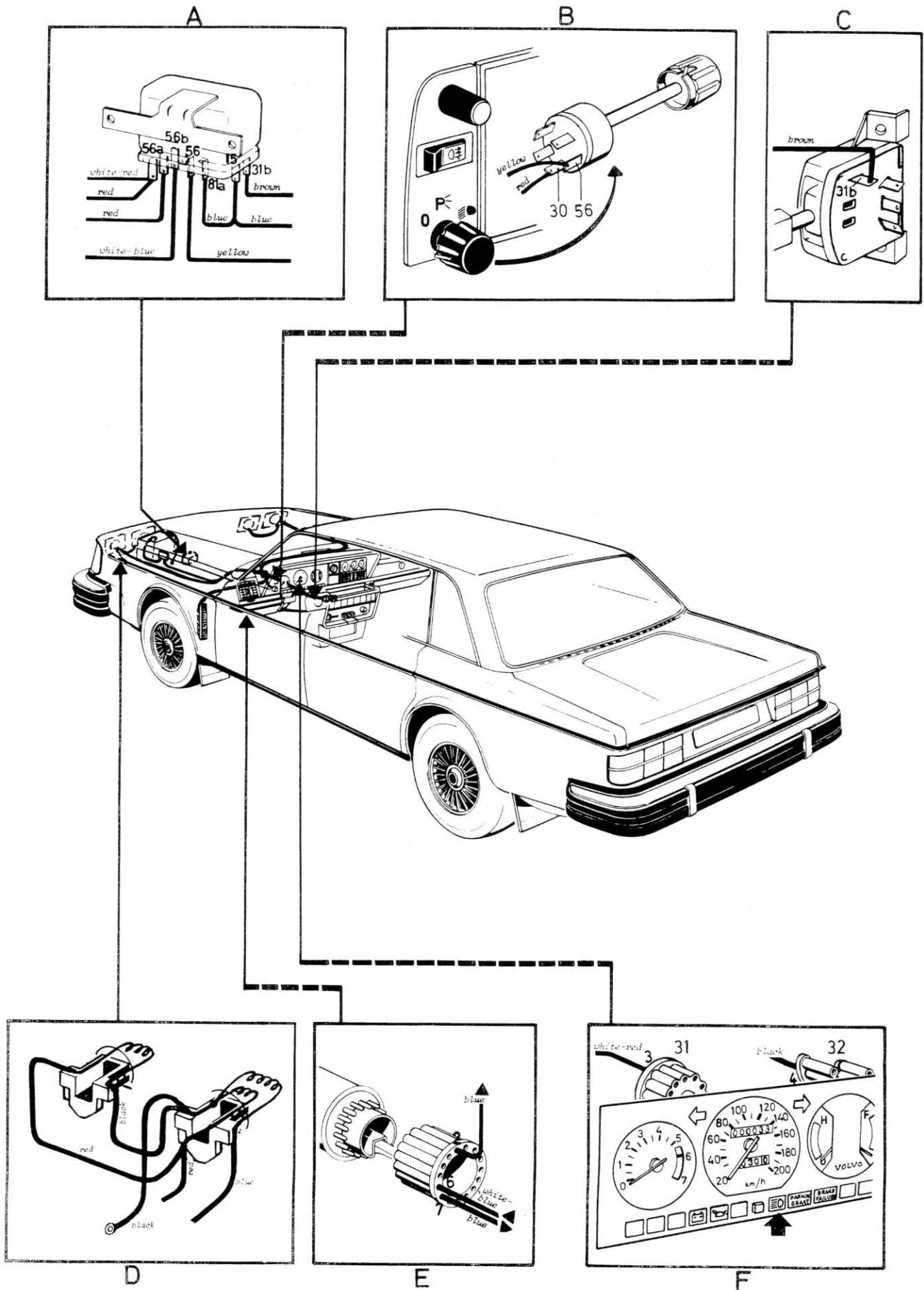

Parking lights, tail lights, license plate lights DL, GL,

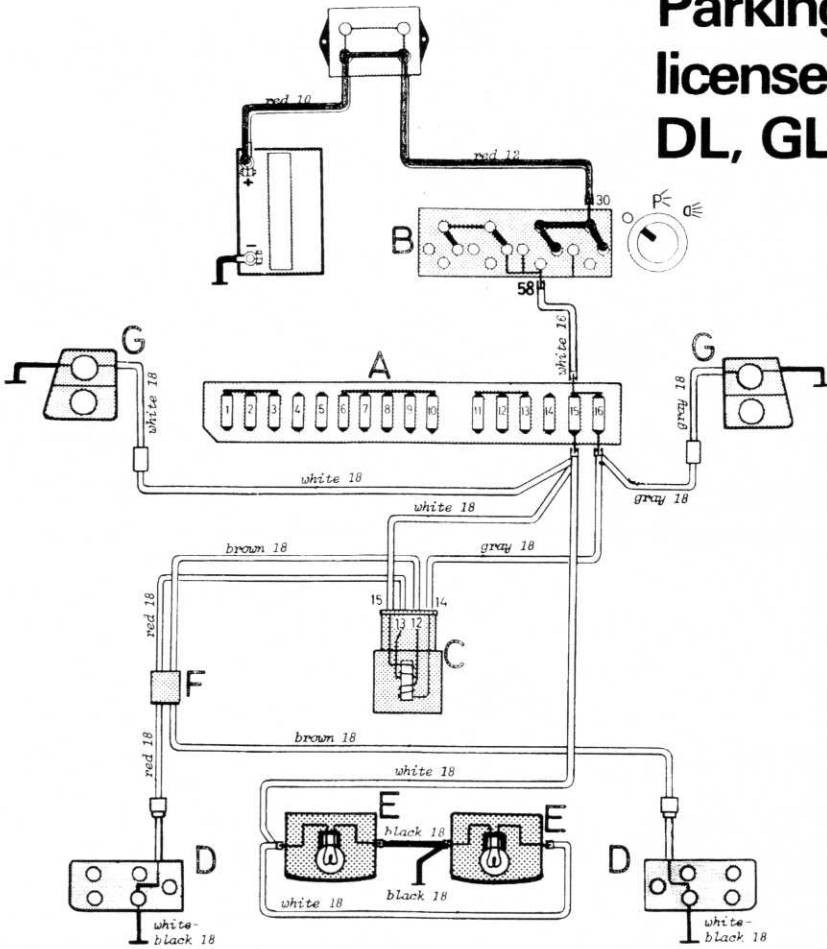

Fuse No. 15:
Parking light, left side
License plate light

Fuse No. 16:
Parking light, right side
Instrument lights
Lights on controls
Buzzer, headlight

Legend:
A Fuse box
B Light switch
C Bulb failure sensor
D Tail lamp
E License plate lamps
F Connector
G Parking lamps

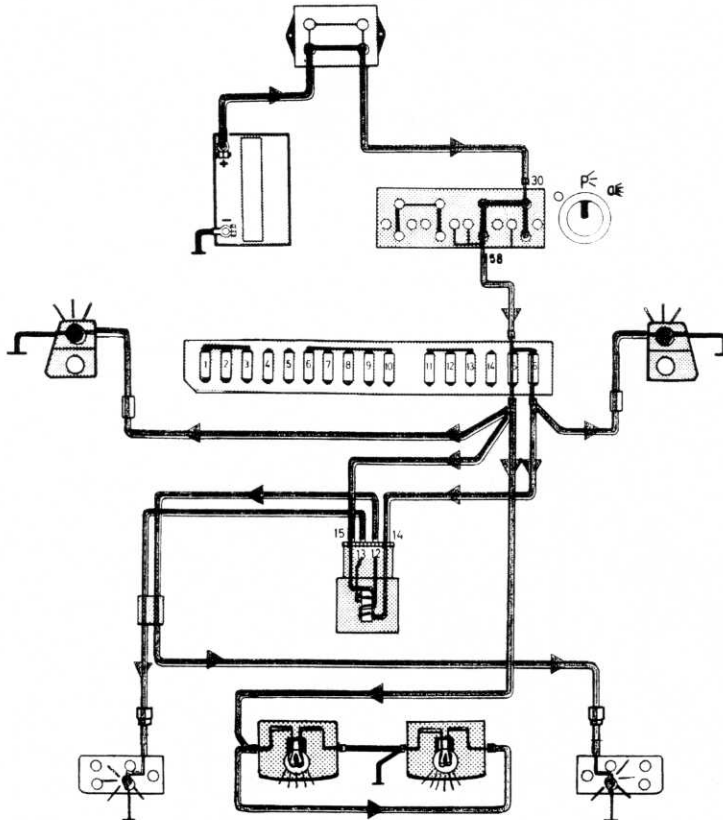

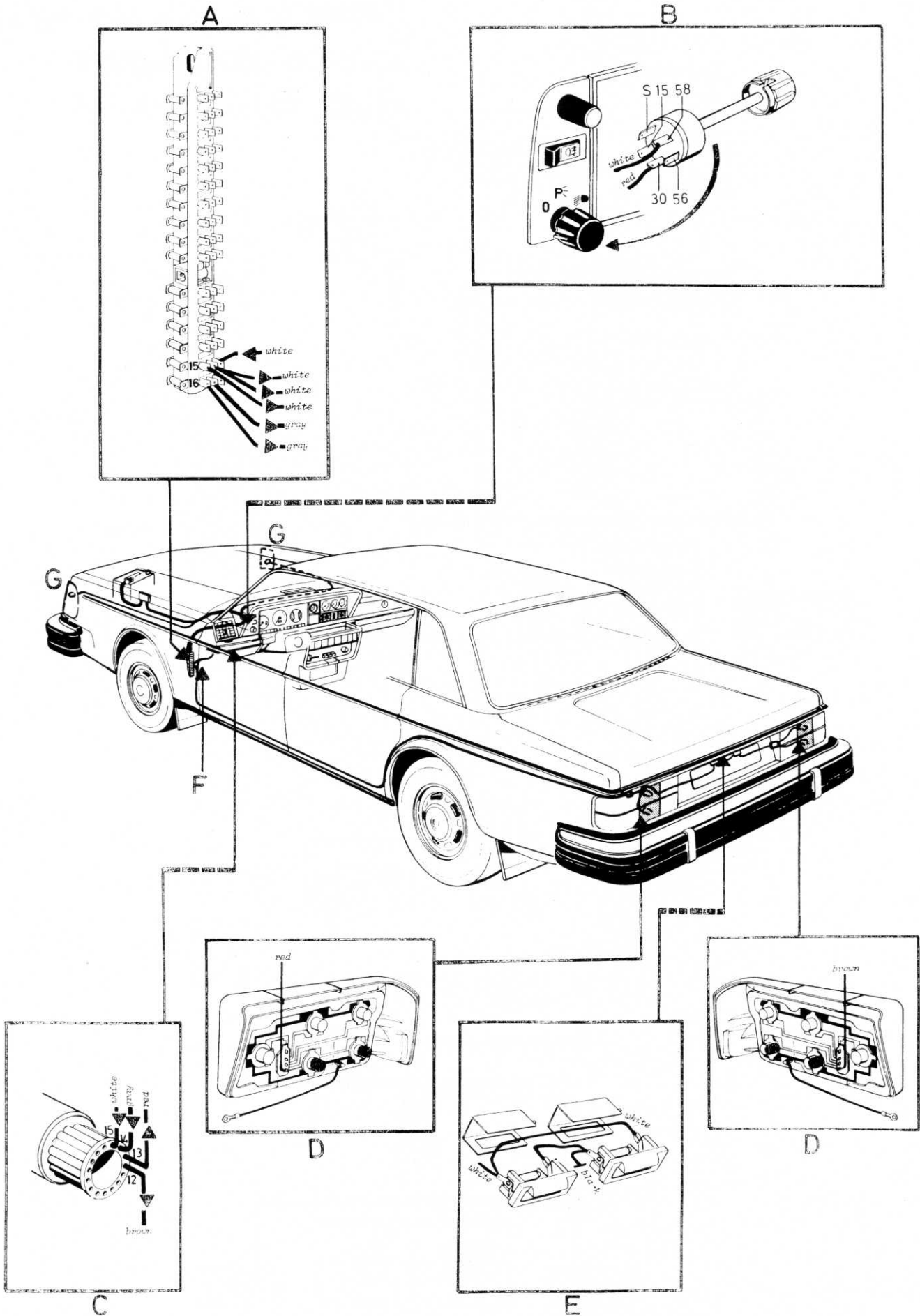

Parking lights, tail lights, license plate lights GLE, GLT, Coupe

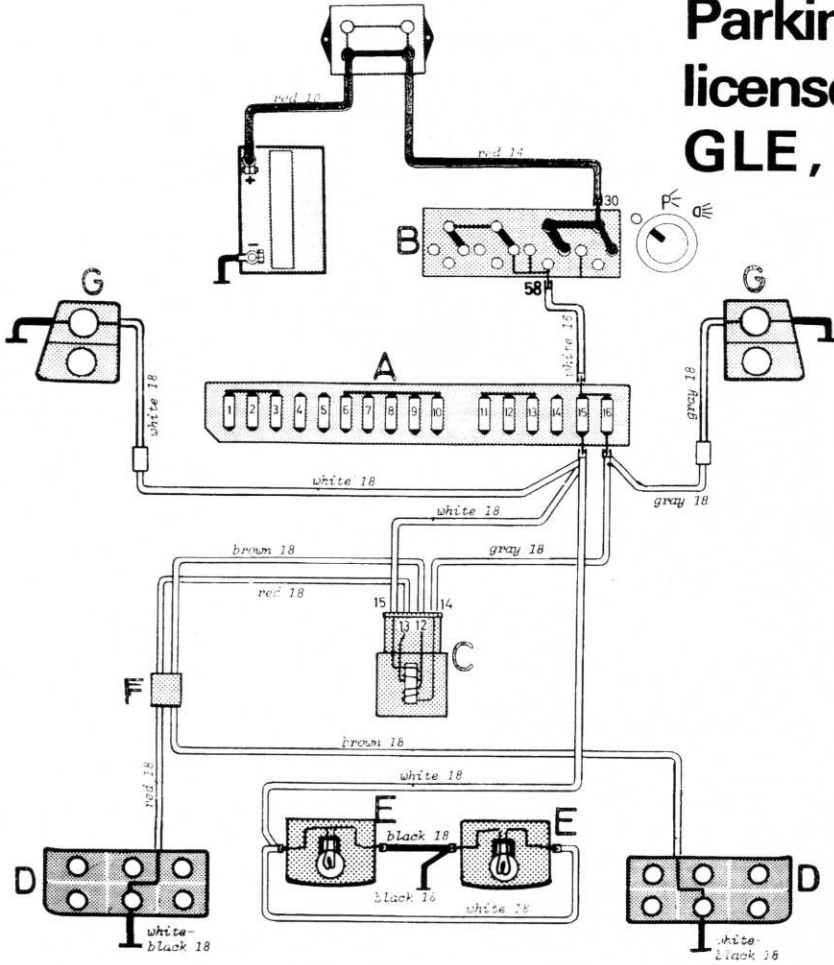

Fuse No. 15:
Parking light, left side
License plate light

Fuse No. 16:
Parking light, right side
Instrument lights
Lights on controls
Buzzer, headlight

Legend:

- A Fuse box
- B Light switch
- C Bulb failure sensor
- D Tail lamp
- E License plate lamp
- F Connector
- G Parking lamp

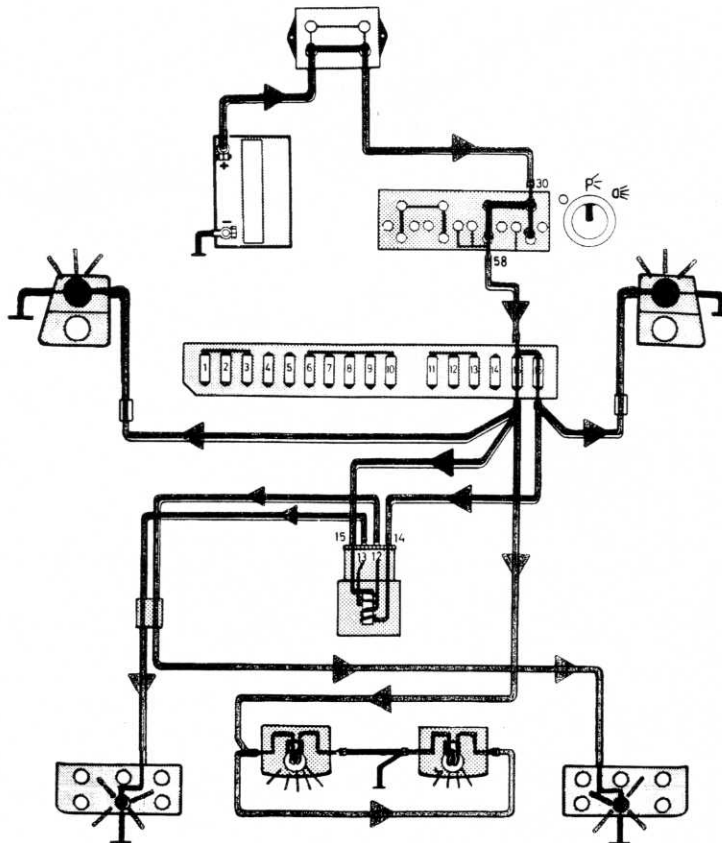

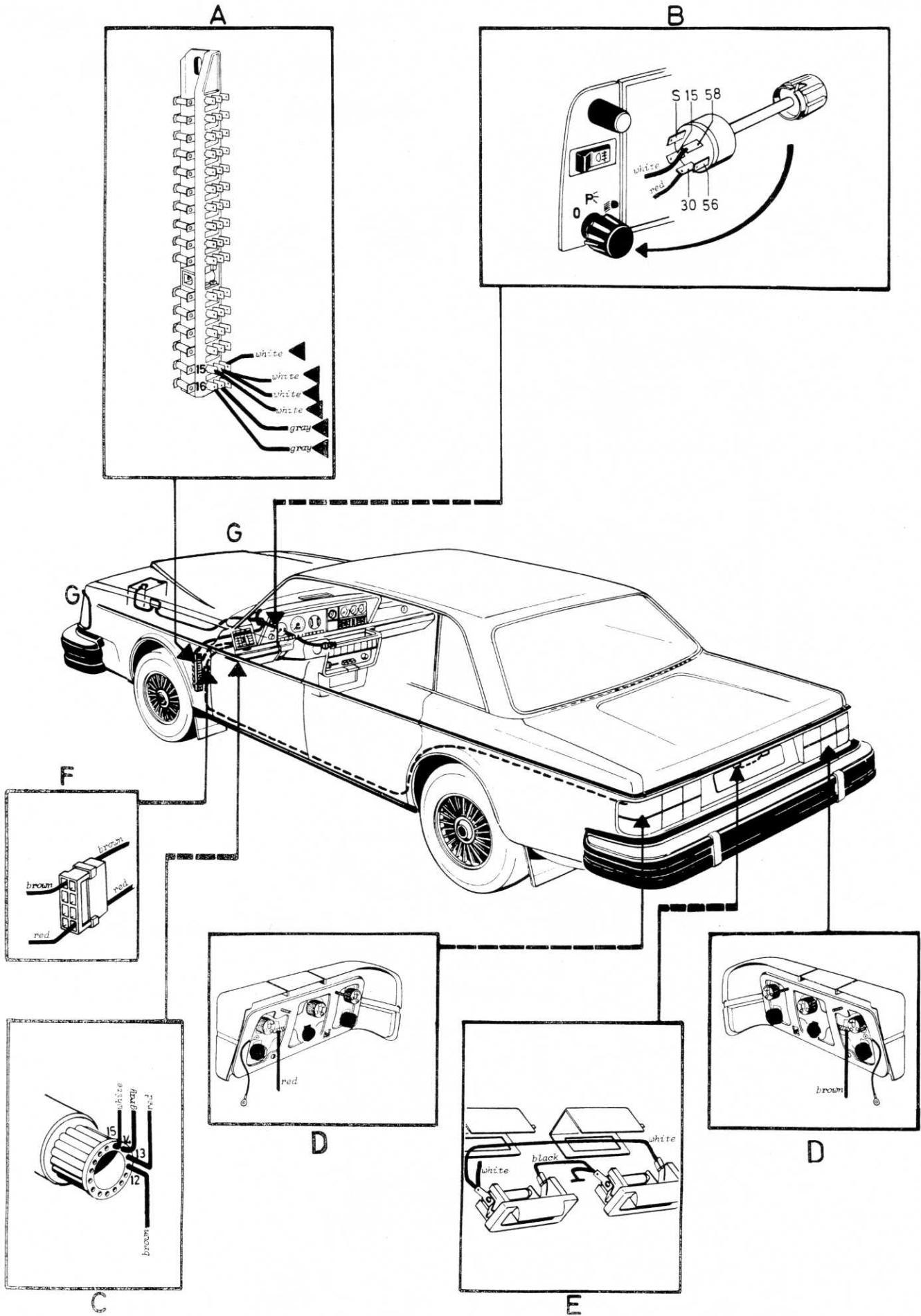

Parking lights, tail lights license plate lights, Wagon

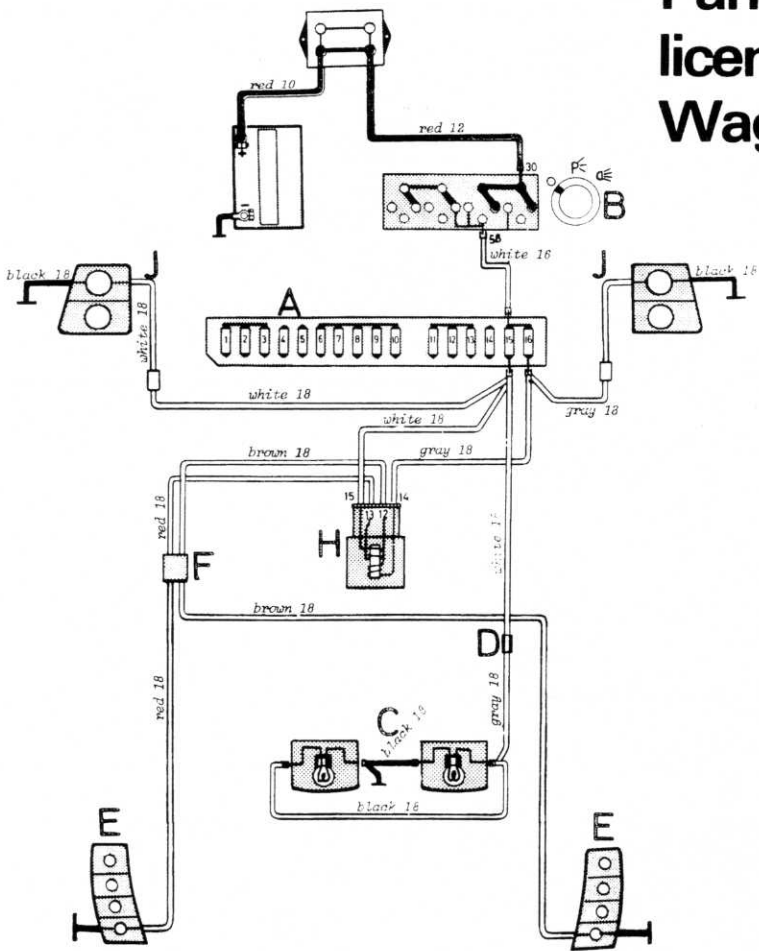

Fuse No. 15:
 Parking light, left side
 License plate light
 Side marker light (wagon)

Fuse No. 16:
 Parking light, right side
 Instrument lights
 Lights on controls
 Buzzer, headlight

- Legend:**
- A Fuse box
 - B Light switch
 - C License plate lamps
 - D Connector
 - E Tail lamps
 - F Connector
 - H Bulb failure sensor
 - J Parking lamps

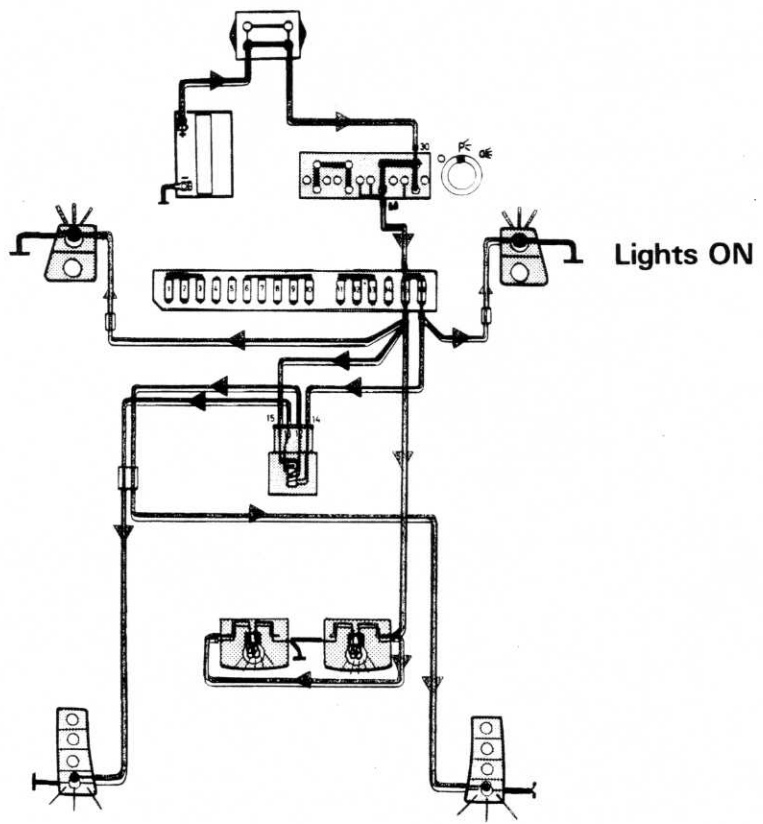

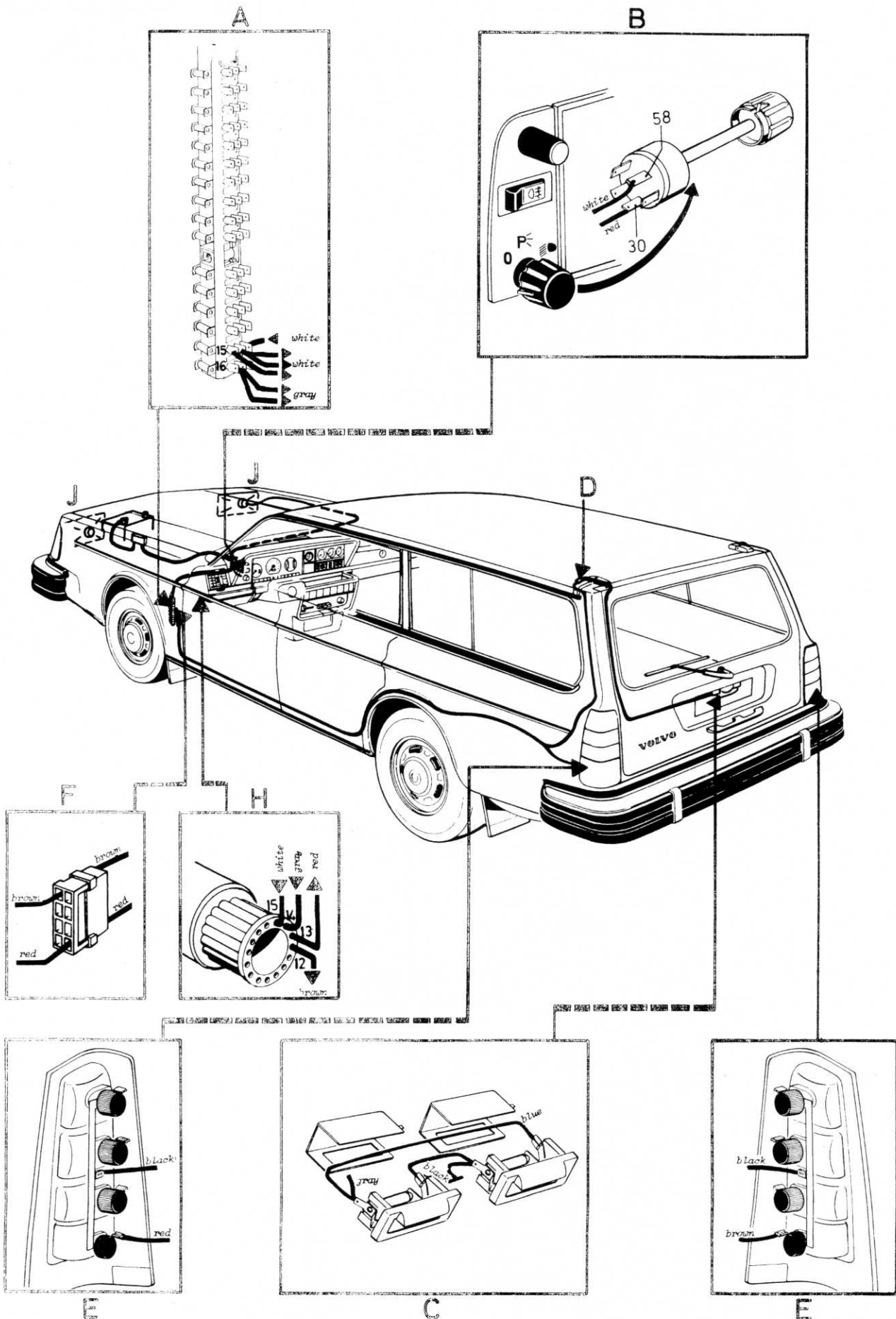

Brake lights DL, GL

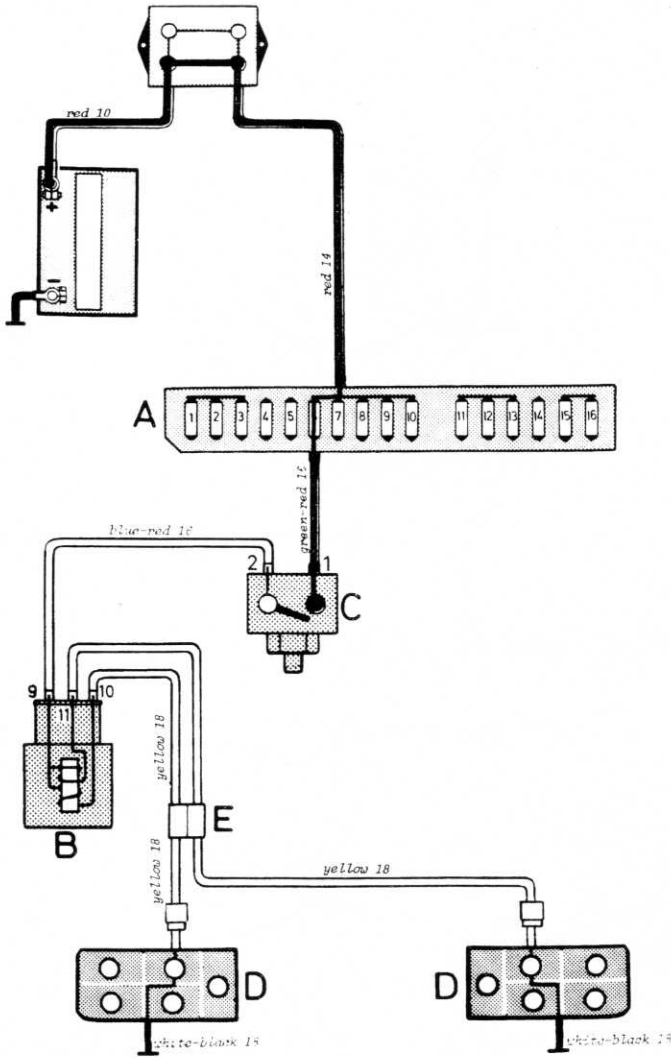

Fuse No. 6:
Brake light

Legend:

- A Fuse box
- B Bulb failure sensor
- C Brake light switch
- D Brake lights
- E Connector

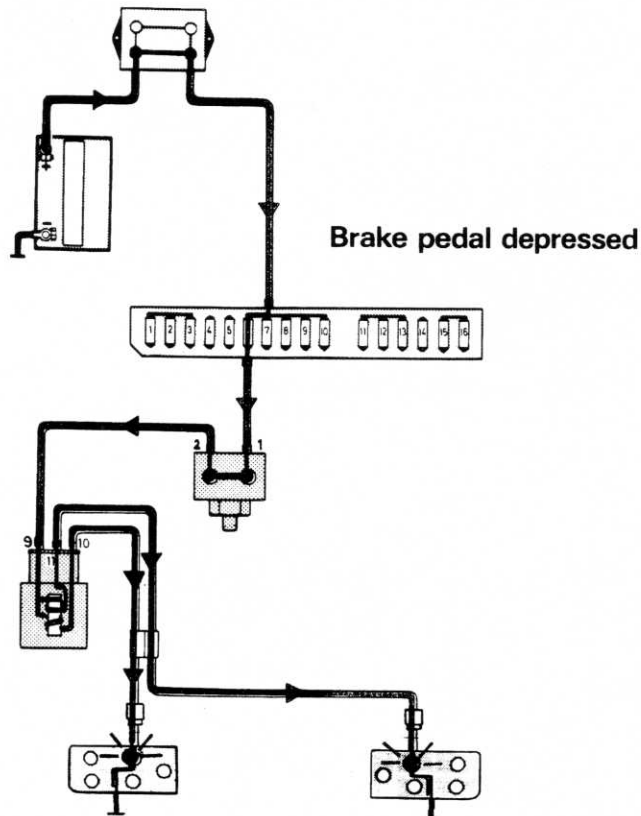

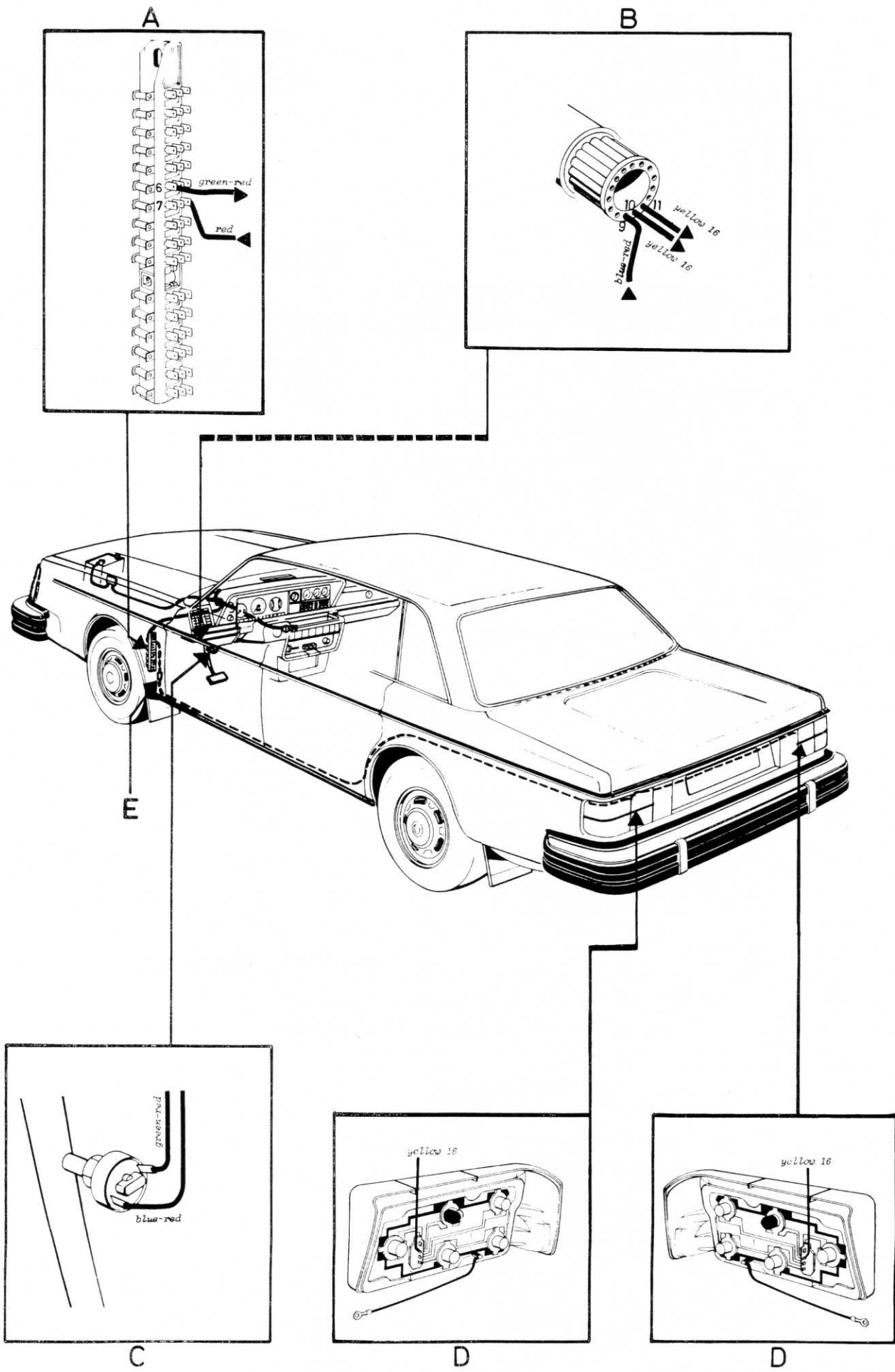

Brake lights GLE, GLT, Coupe

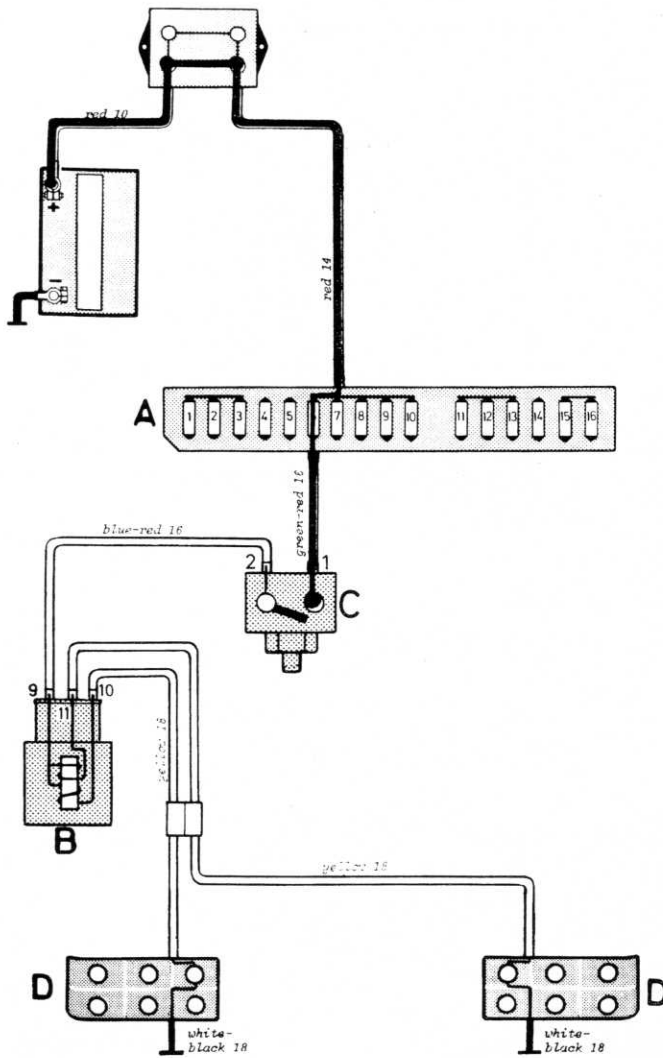

Fuse No. 6:
Brake light

Legend:
A Fuse box
B Bulb failure sensor
C Brake light switch
D Brake lights

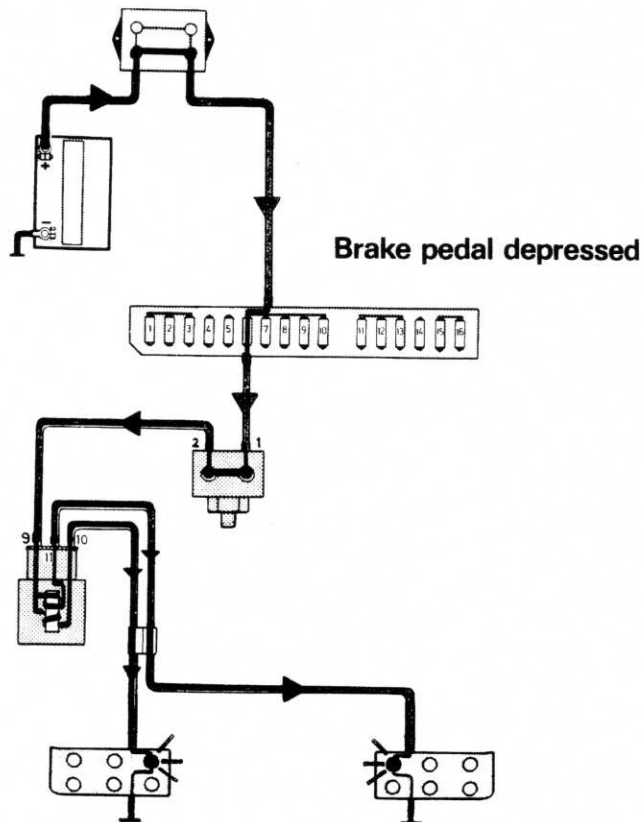

Brake pedal depressed

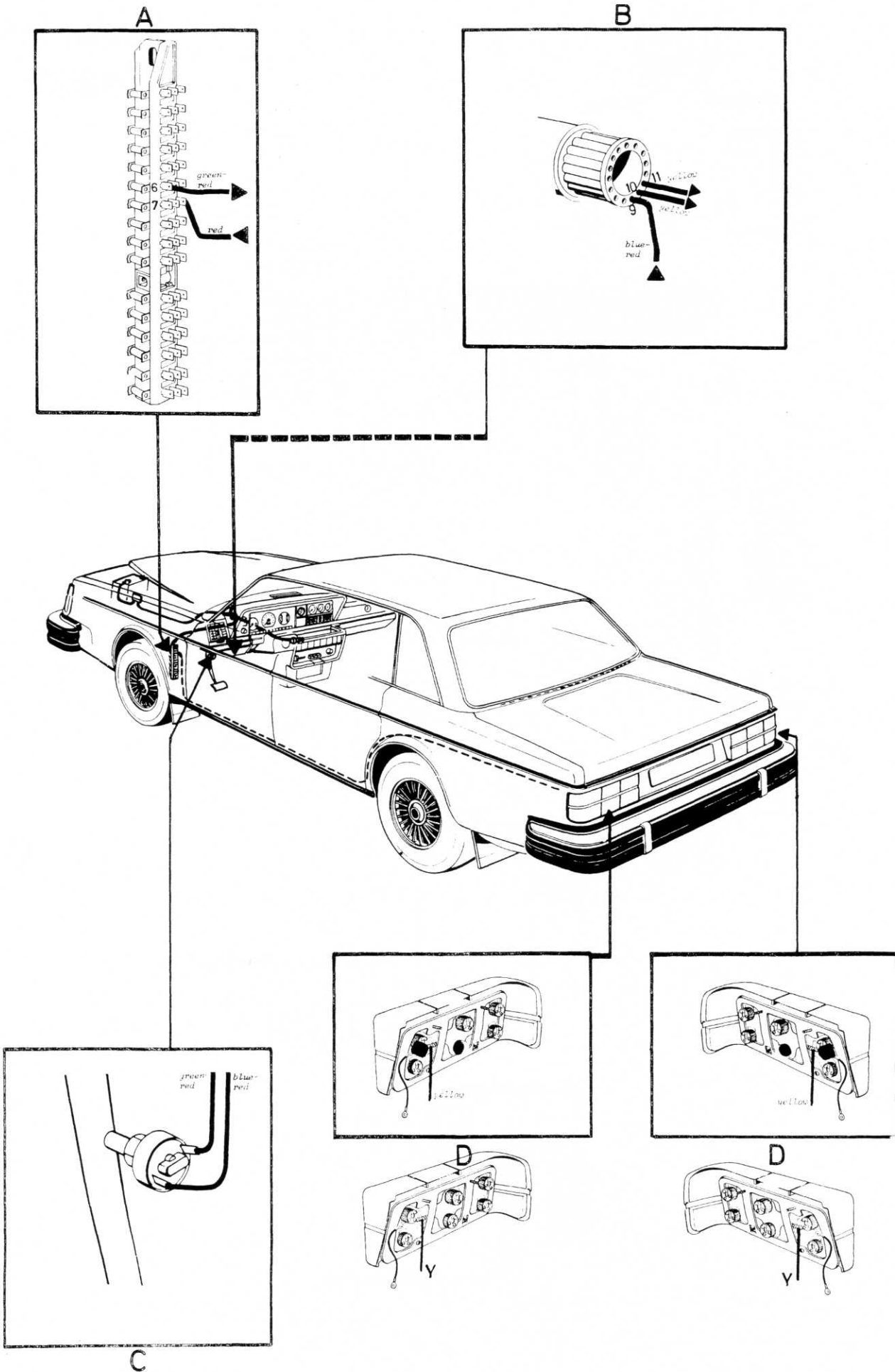

Brake lights Wagon

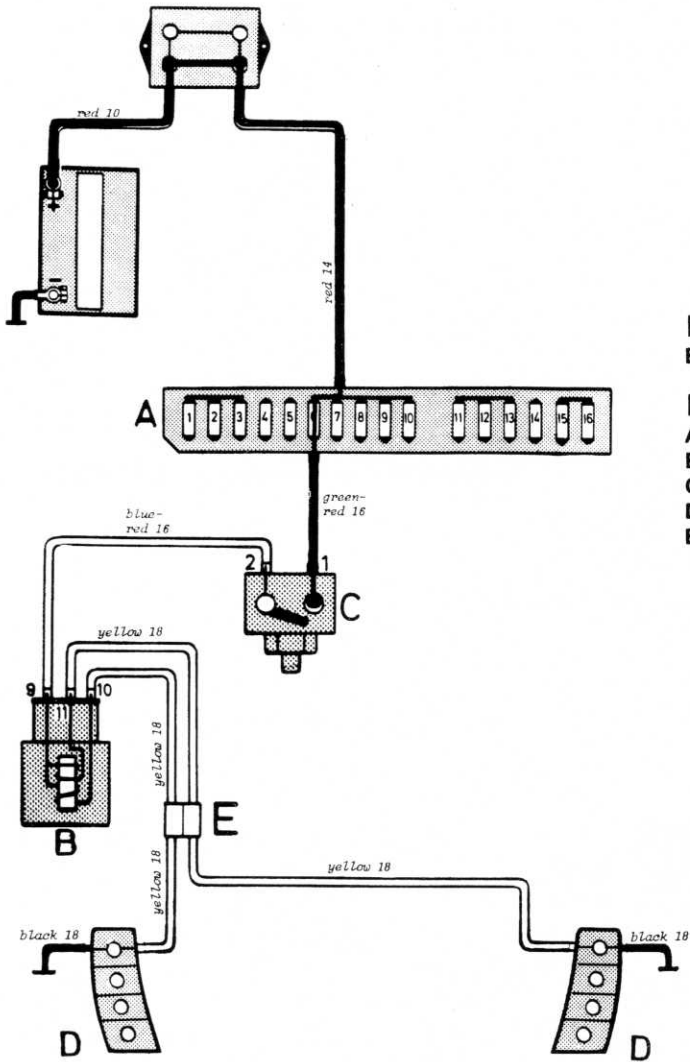

Fuse No. 6:
Brake light

Legend:
A Fuse box
B Bulb failure sensor
C Brake light switch
D Brake lights
E Connector

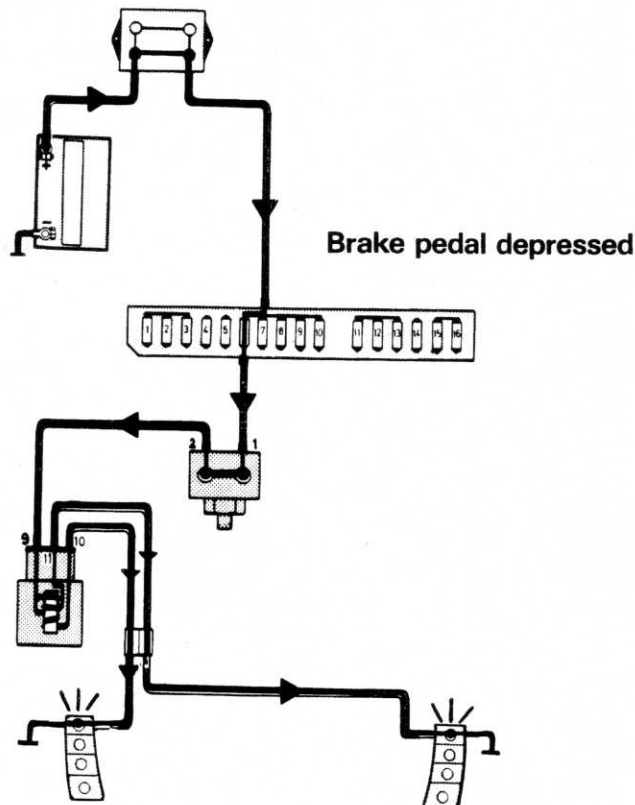

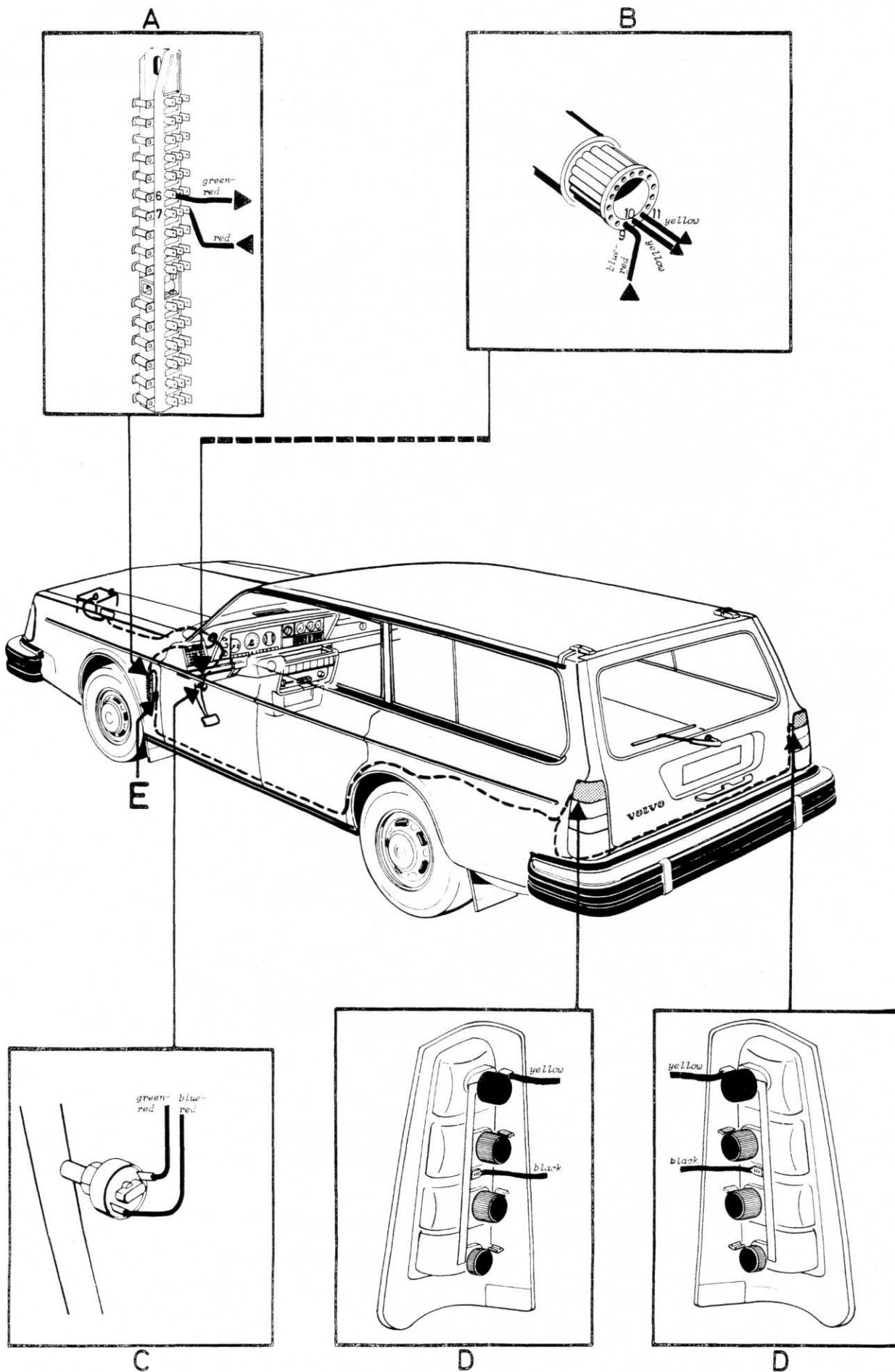

Back-up lights, manual transmission DL, GL

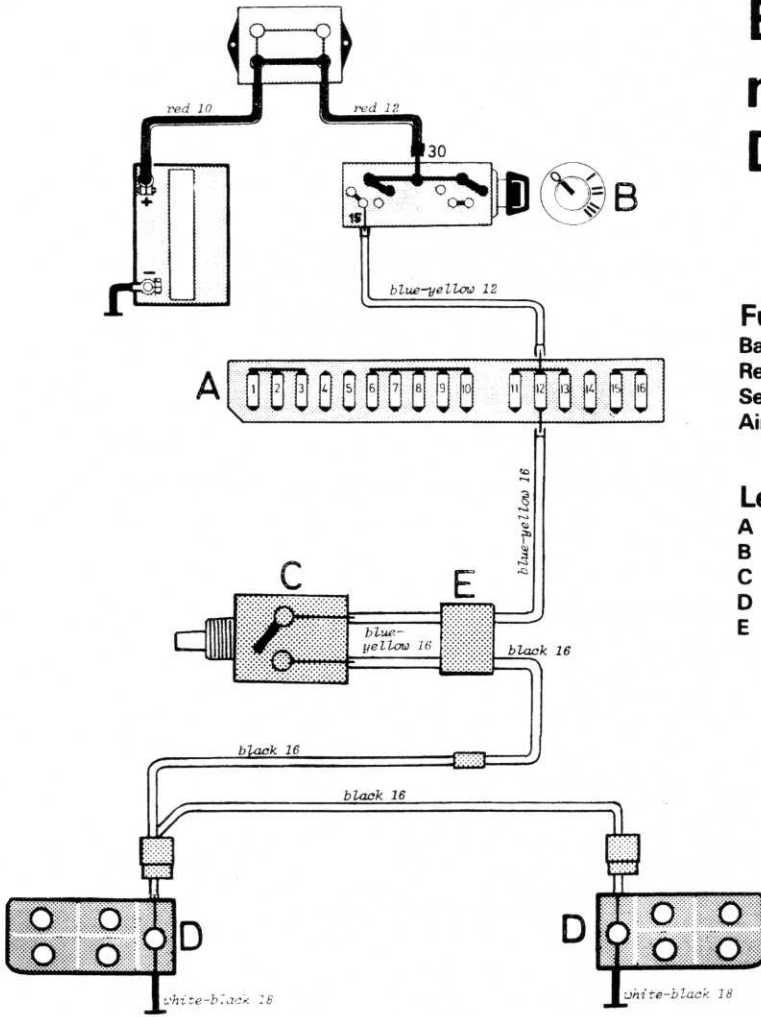

Fuse No. 12:
Back-up lights
Relay, window lifts
Seat heater
Air conditioning

Legend:
A Fuse box
B Ignition switch
C Back-up light switch
D Back-up lights
E Connector

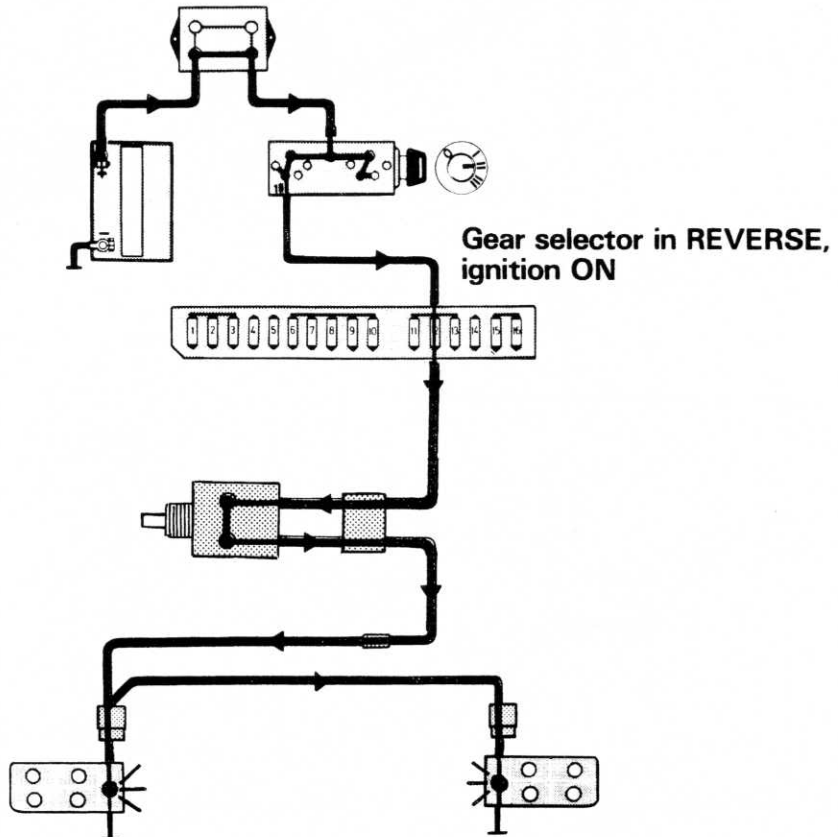

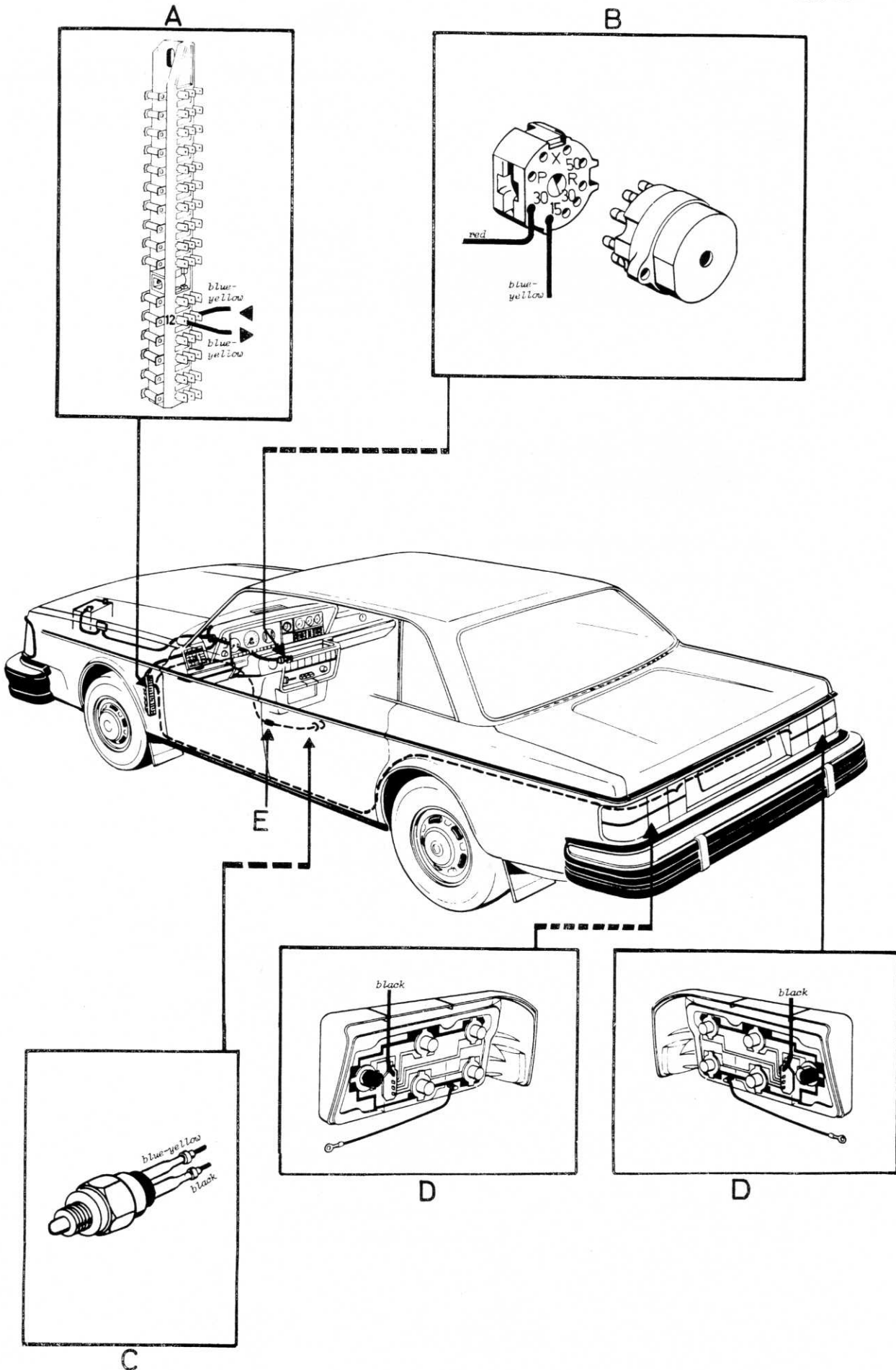

Back-up lights, manual transmission GLE, GLT, Coupe

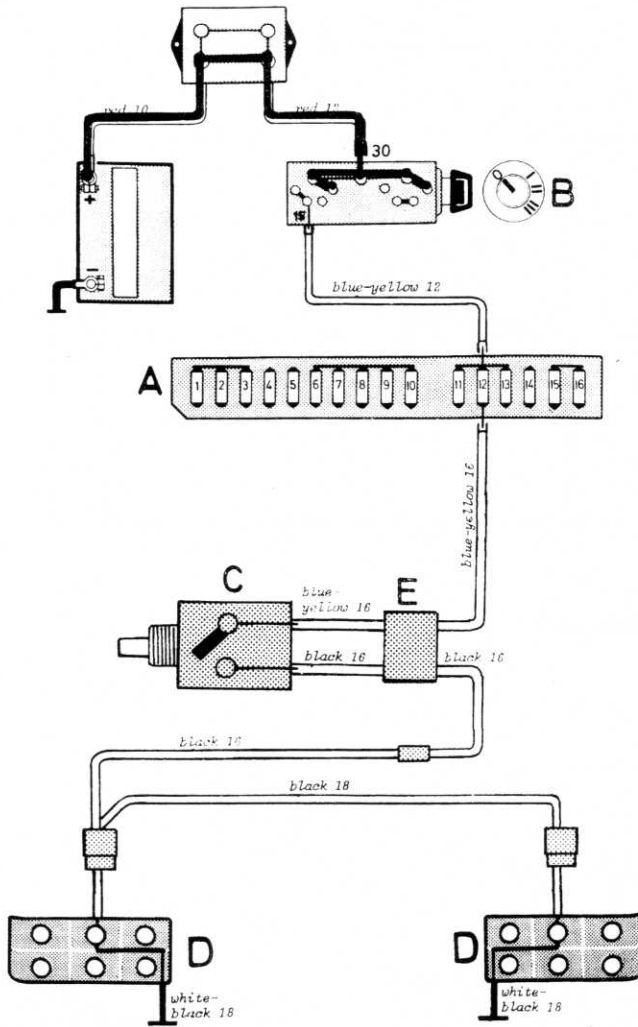

Fuse No. 12:
Back-up lights
Relay, window lifts
Seat heater
Air conditioning

Legend:
A Fuse box
B Ignition switch
C Back-up light switch
D Back-up light
E Connector

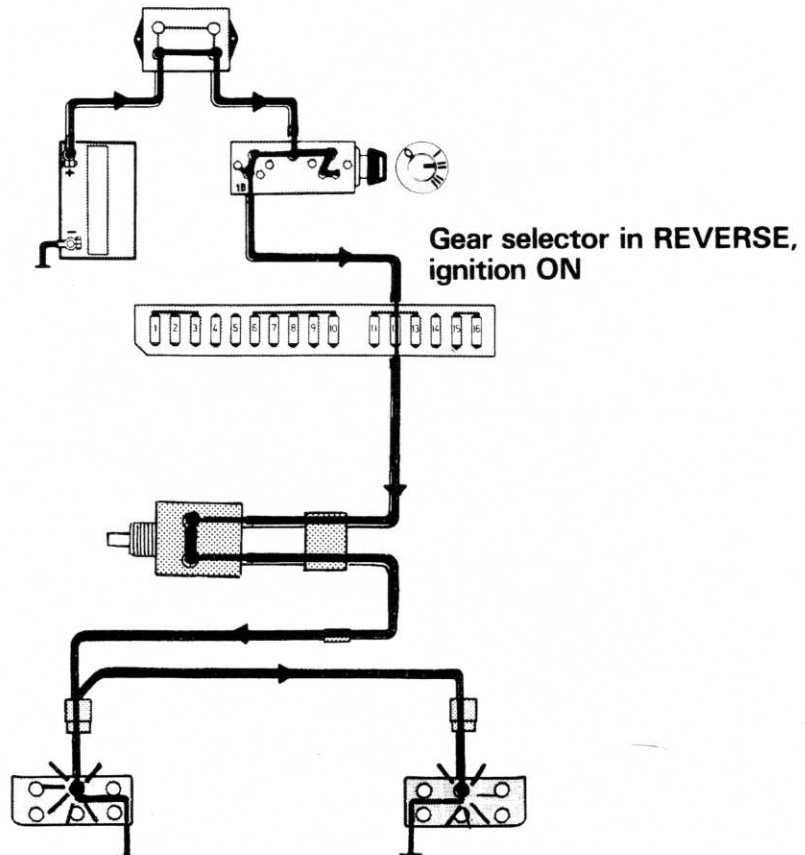

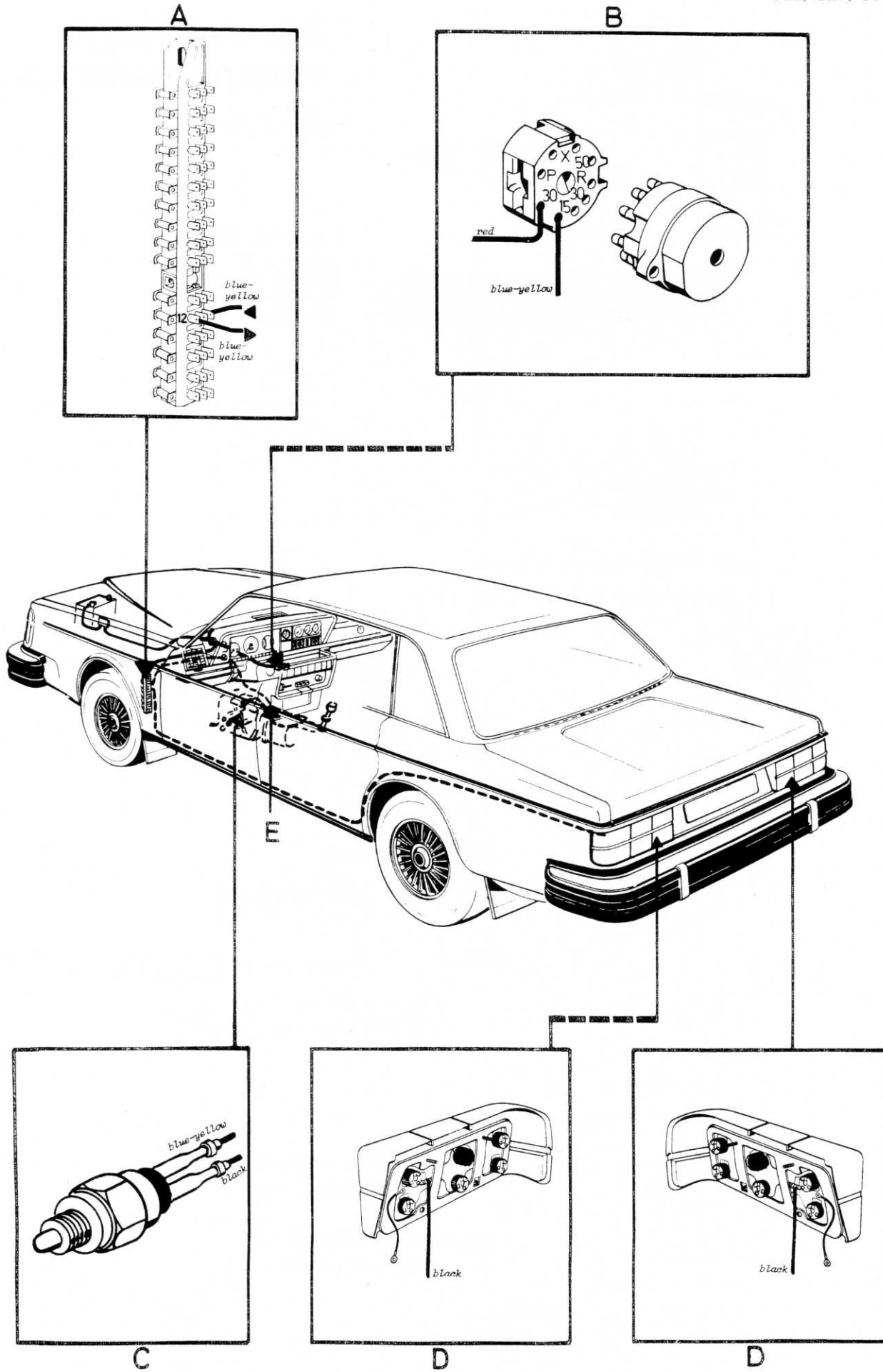

Back-up lights, manual transmission Wagon

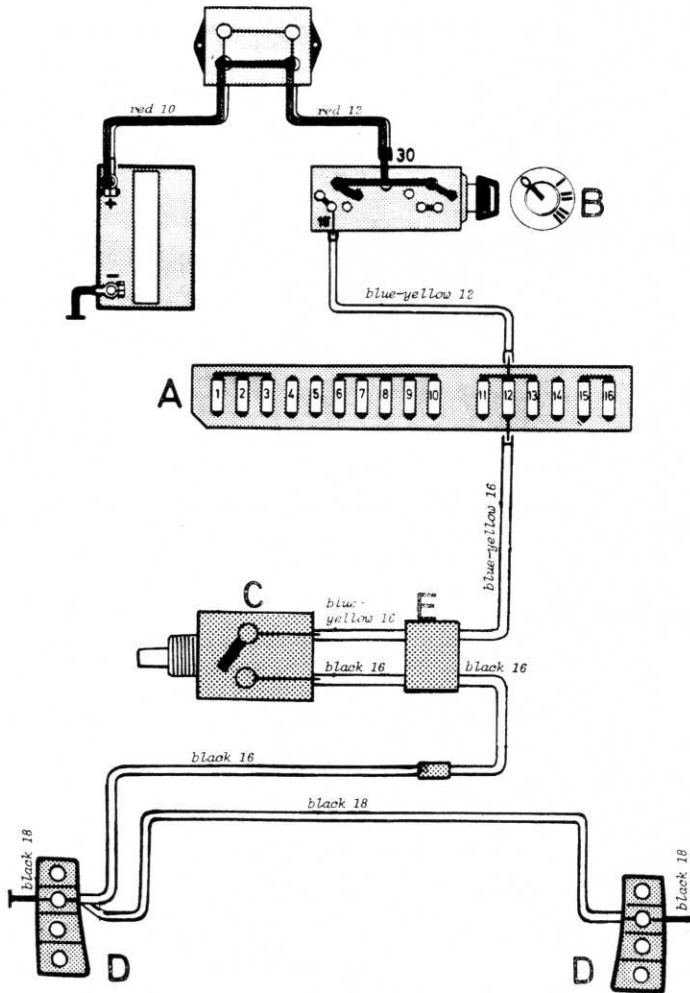

Fuse No. 12:
Back-up lights
Relay, window lifts
Seat heater
Air conditioning

Legend:
A Fuse box
B Ignition switch
C Back-up light switch
D Back-up lights
E Connector

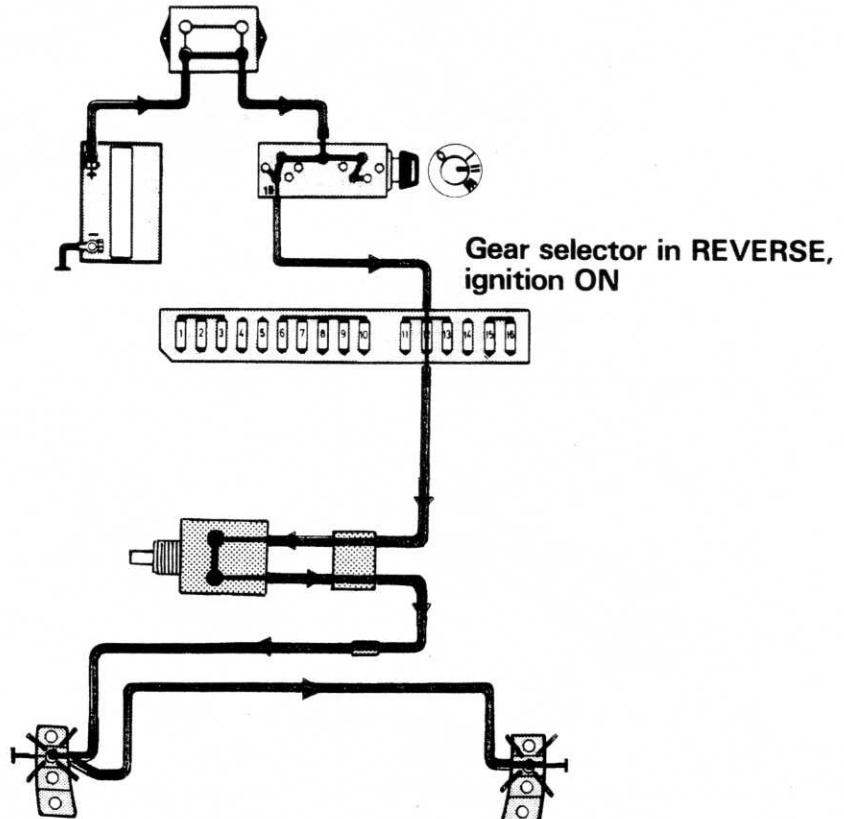

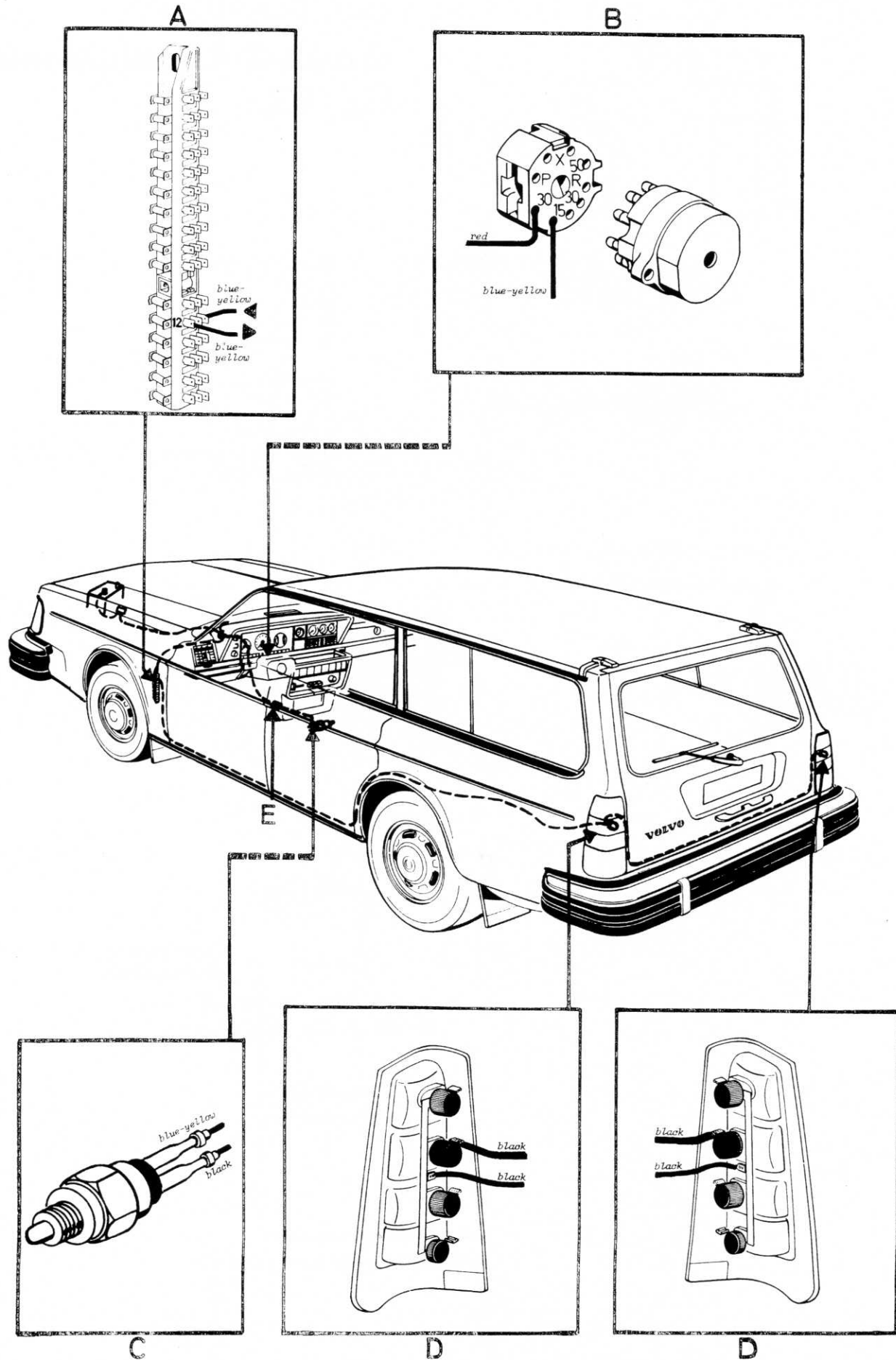

Back-up lights, automatic transmission DL, GL

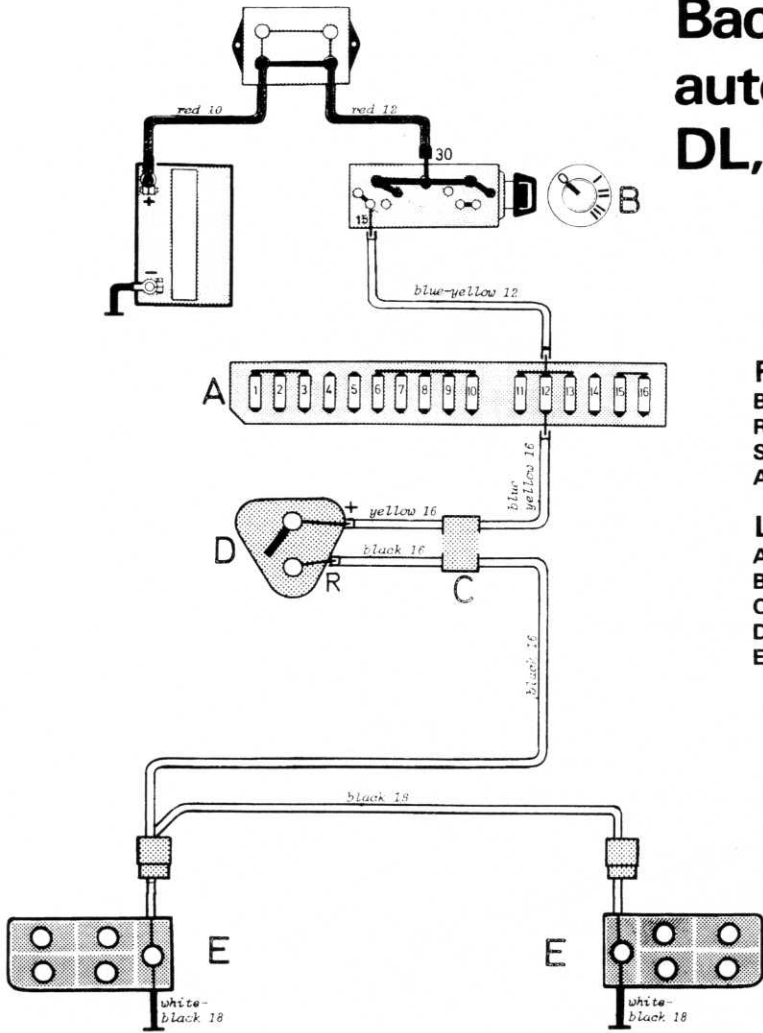

Fuse No. 12:
Back-up lights
Relay, window lifts
Seat heater
Air conditioning

Legend:
A Fuse box
B Ignition switch
C Connector
D Back-up light switch
E Back-up lights

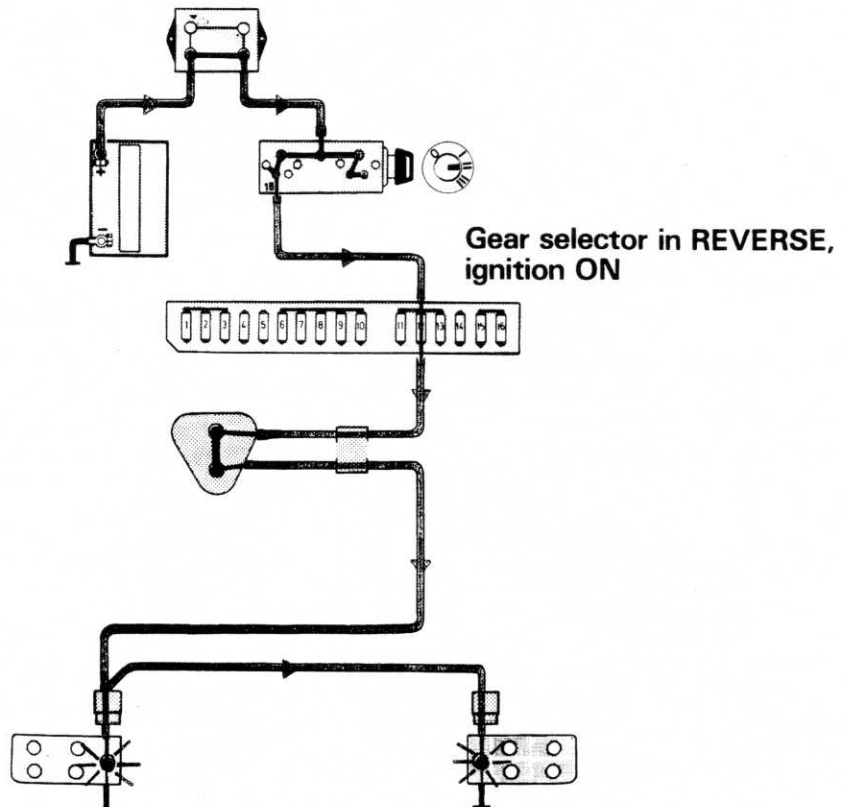

Back-up lights, automatic transmission GLE, Coupe

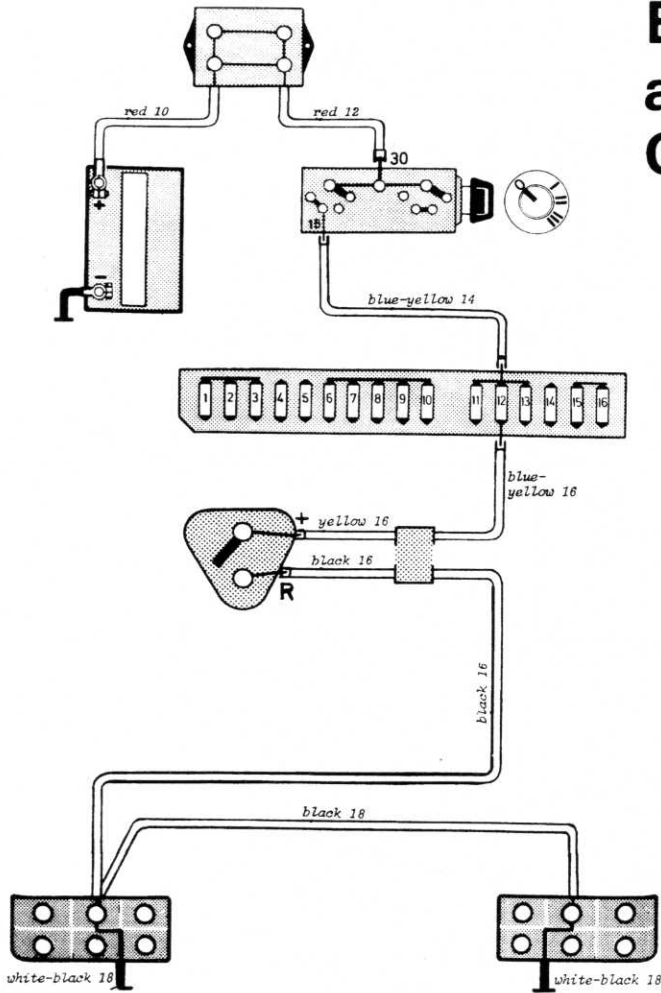

Fuse No. 12:
Back-up lights
Relay, window lifts
Seat heater
Air conditioning

Legend:
A Fuse box
B Ignition switch
C Connector
D Back-up light switch
E Back-up lights

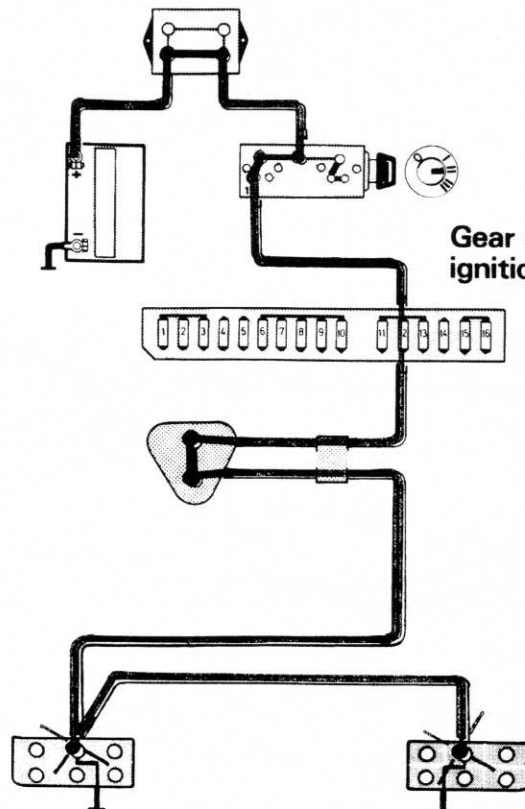

**Gear selector in REVERSE,
ignition ON**

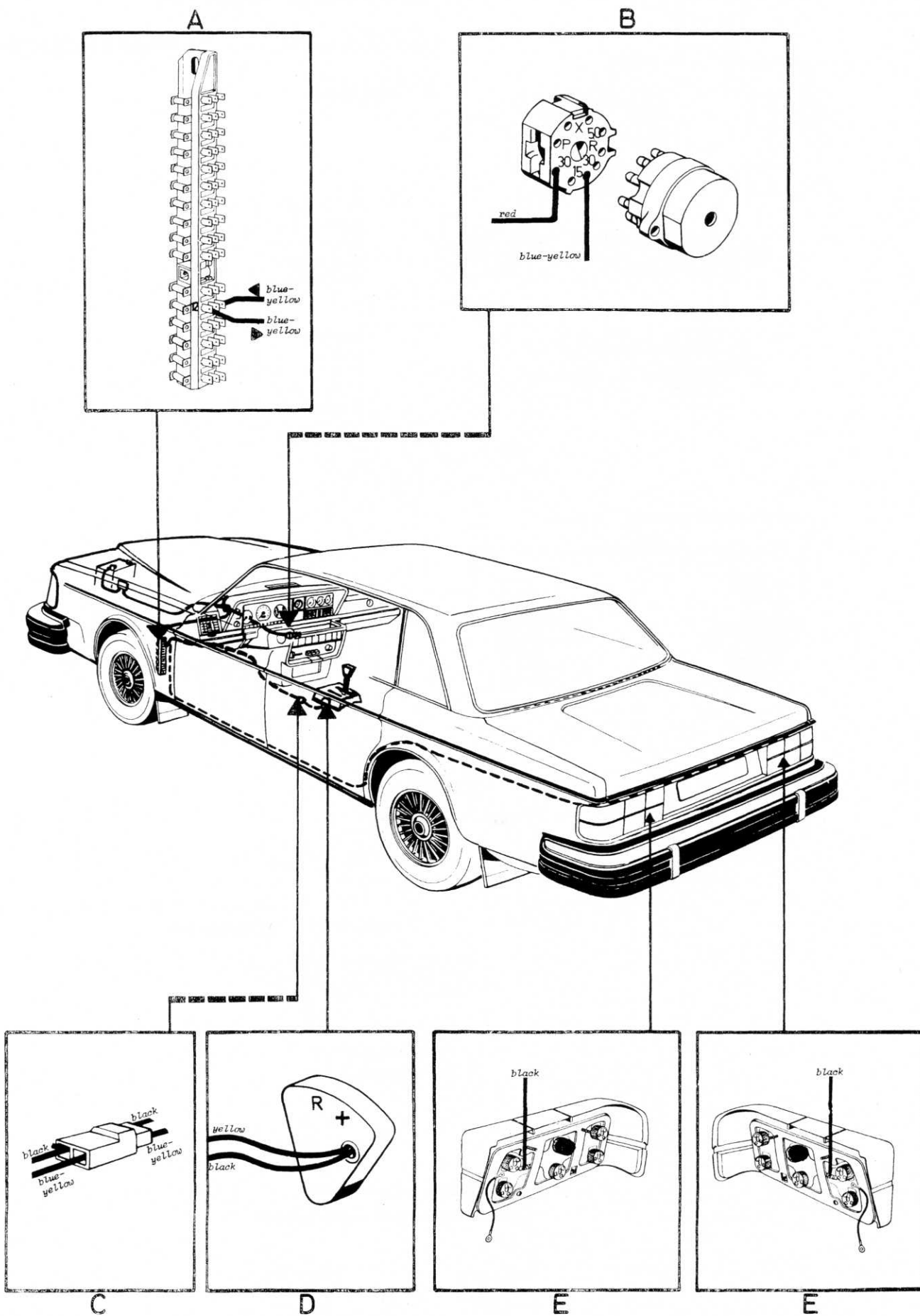

Back-up lights, automatic transmission Wagon

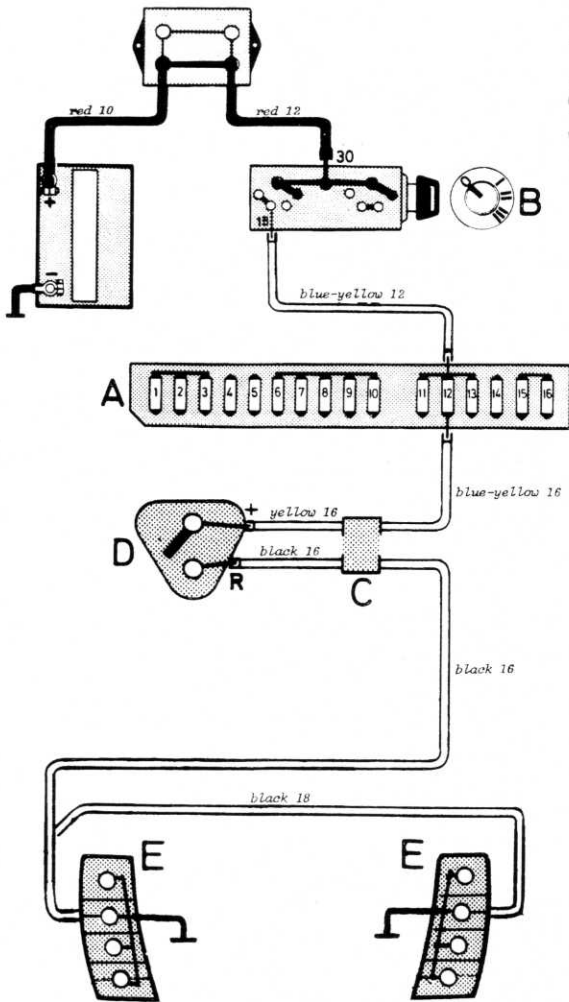

Fuse No. 12:
Back-up lights
Relay, window lifts
Seat heater
Air conditioning

Legend:
A Fuse box
B Ignition switch
C Connector
D Back-up light switch
E Back-up light

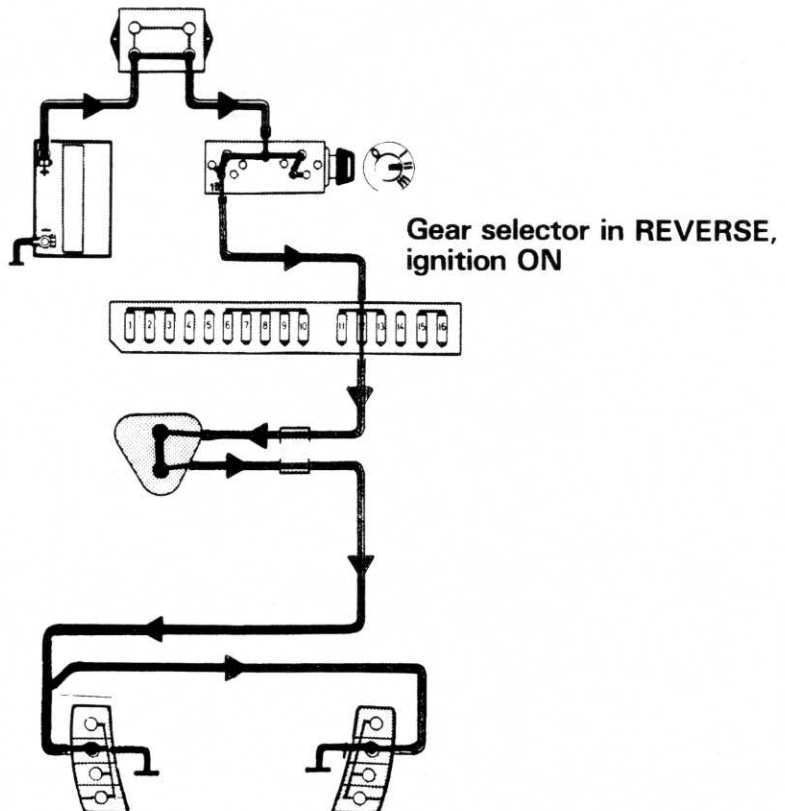

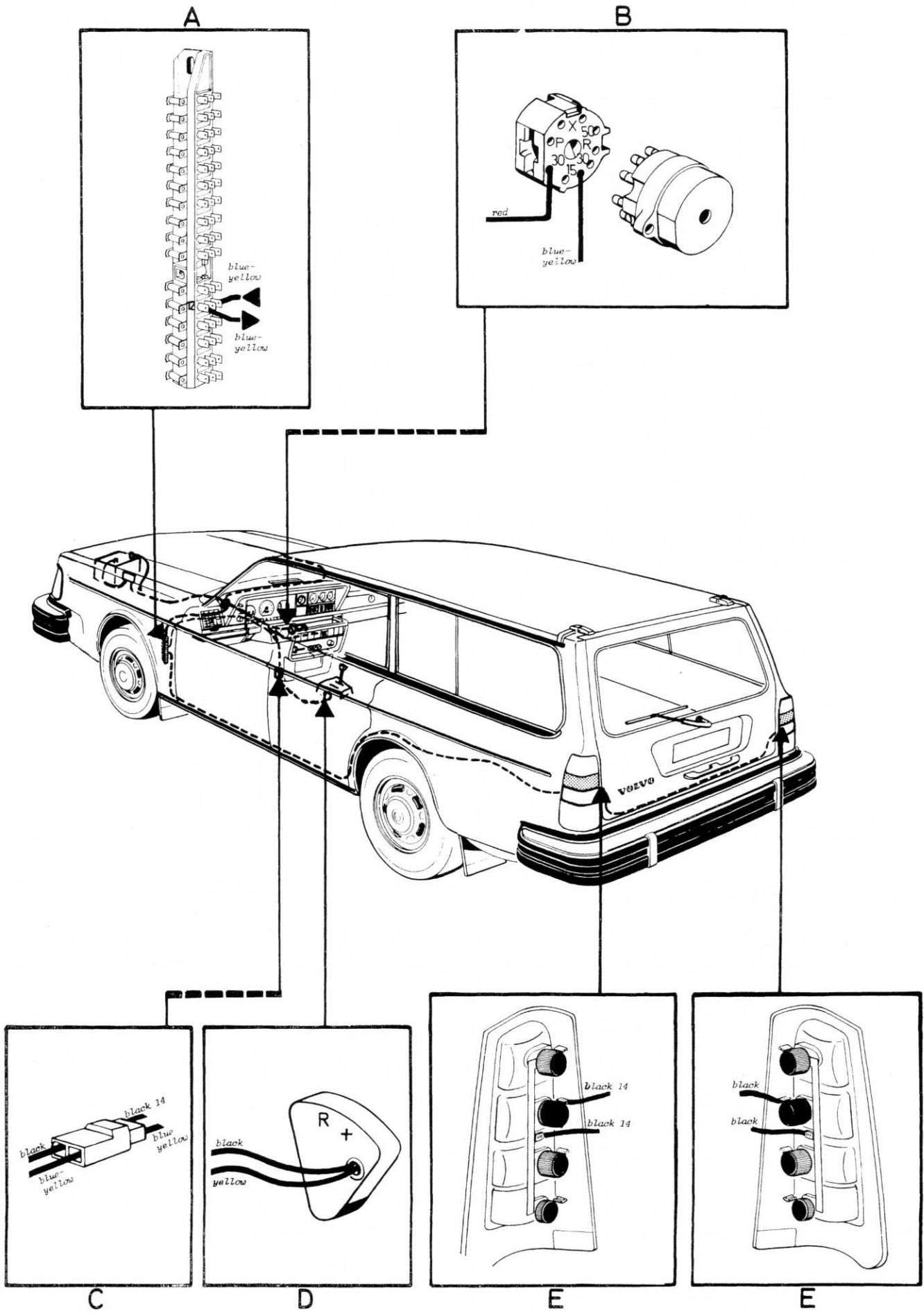

Interior light DL, GL, GLT

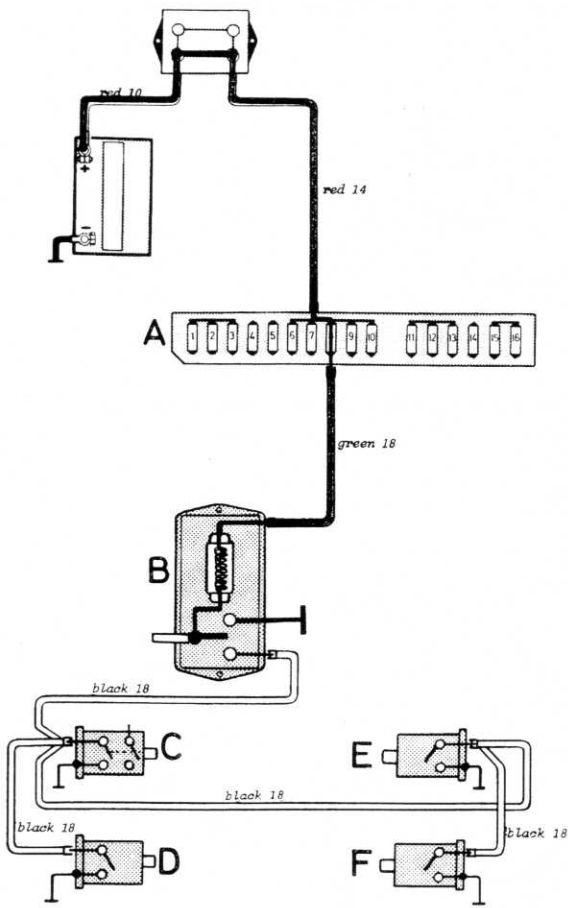

Fuse No. 8:
Interior light
Glove box light
Trunk light
Engine compartment light
Clock

Legend:
A Fuse box
B Interior light
Door switches:
C Front left
D Rear left
E Front right
F Rear right

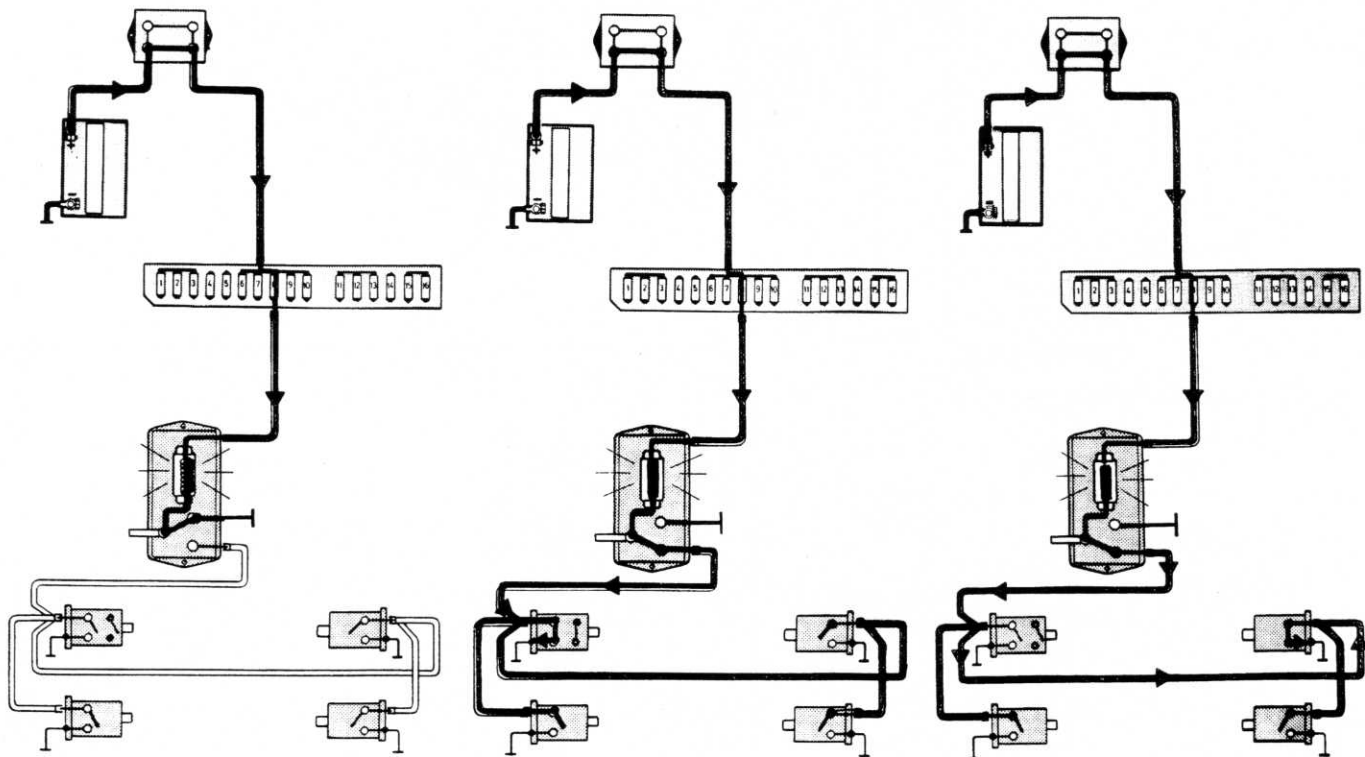

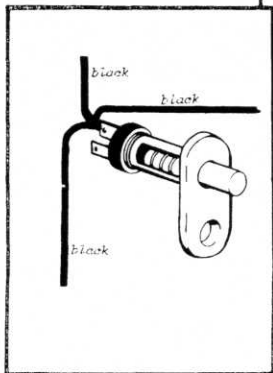
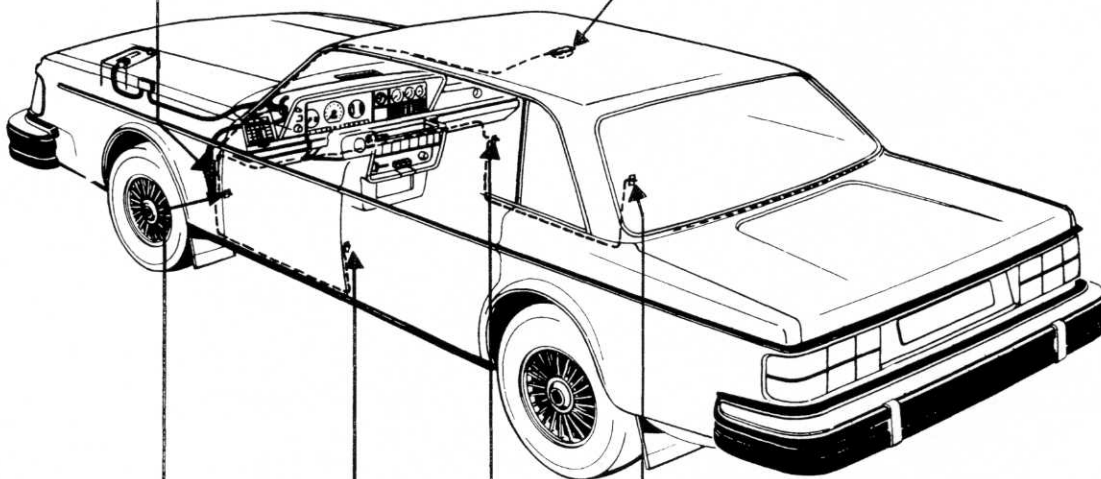
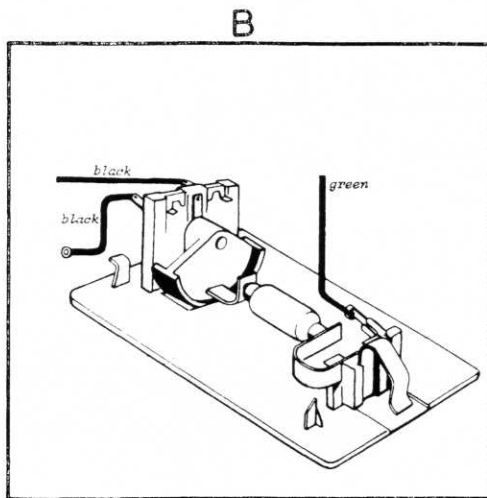
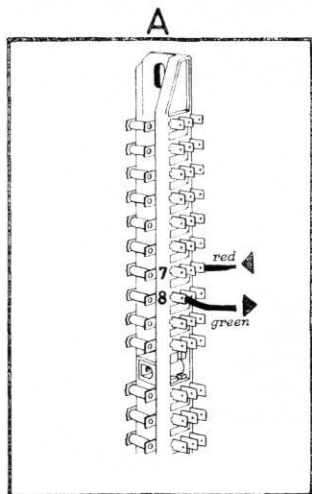

C

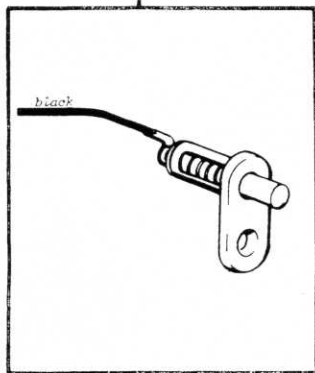

D

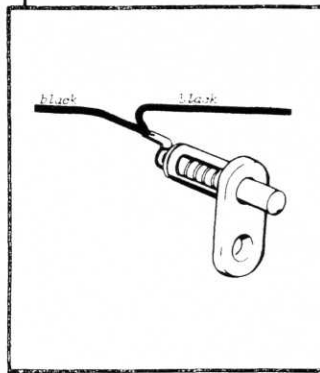

E

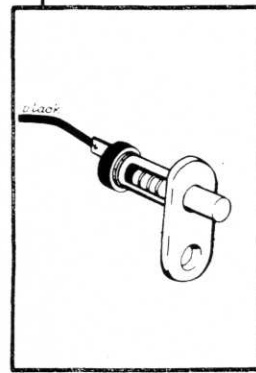

F

Rear interior light Wagon

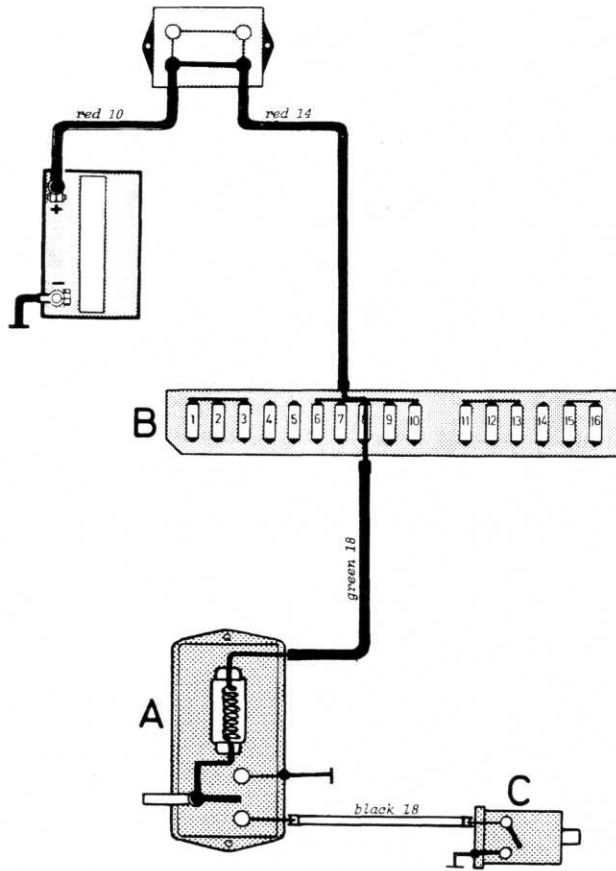

Fuse No. 8:
Interior light
Glove box light
Trunk light
Engine compartment light
Clock

Legend:
A Rear interior light
B Fuse box
C Tail gate switch

**Tail gate closed,
rear interior light ON**

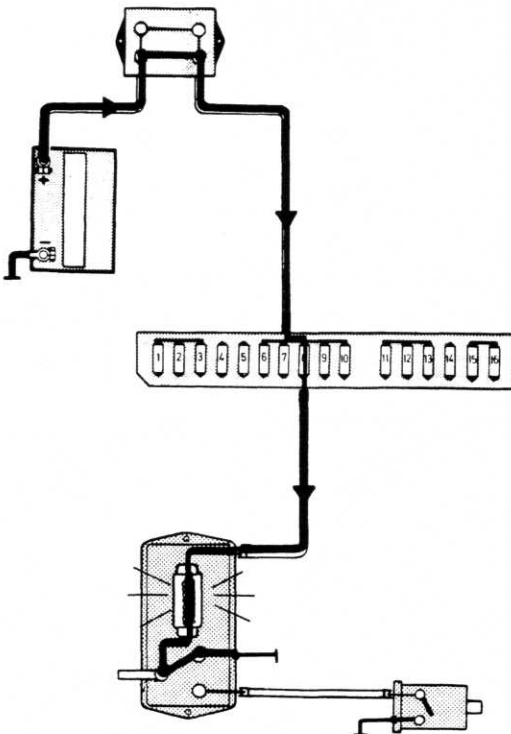

Tail gate opened

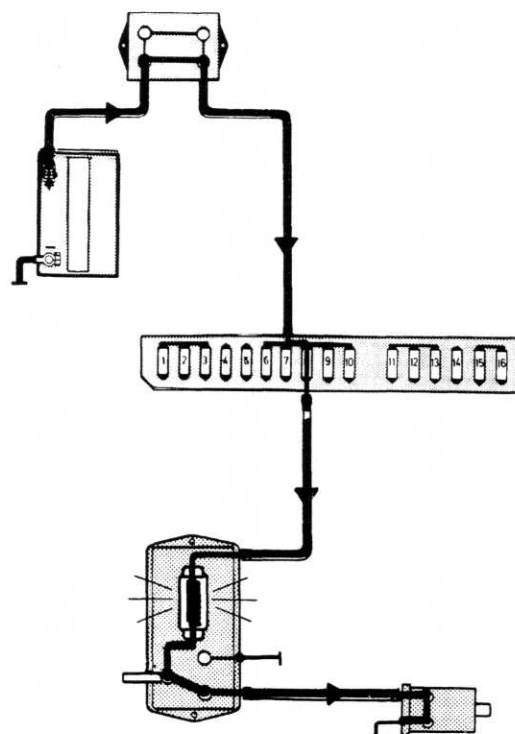

A

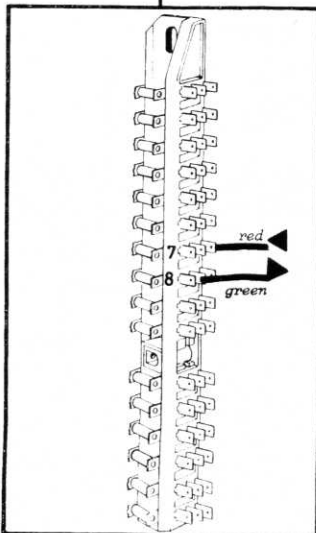
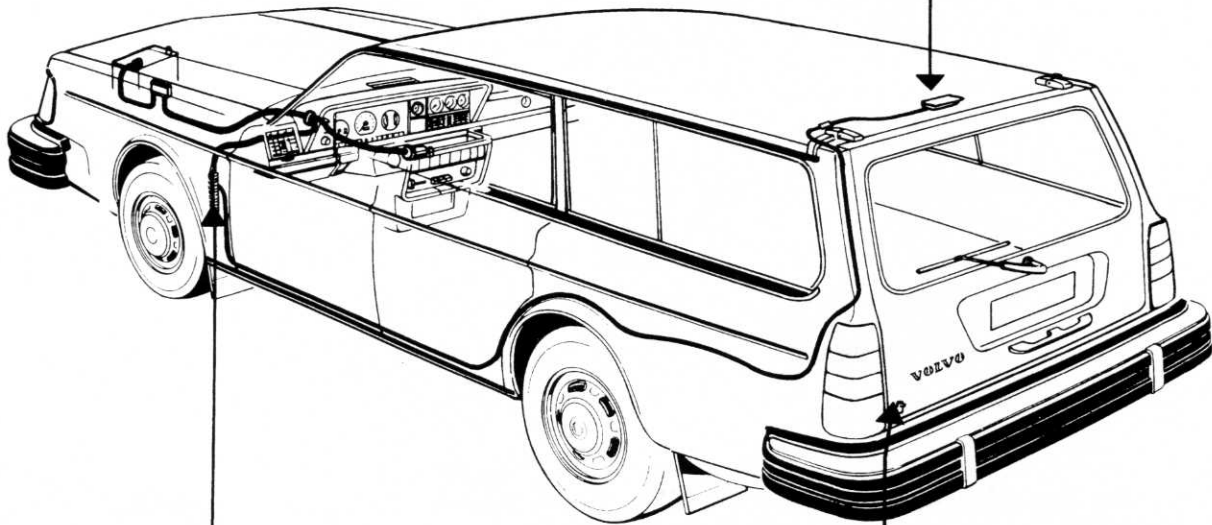
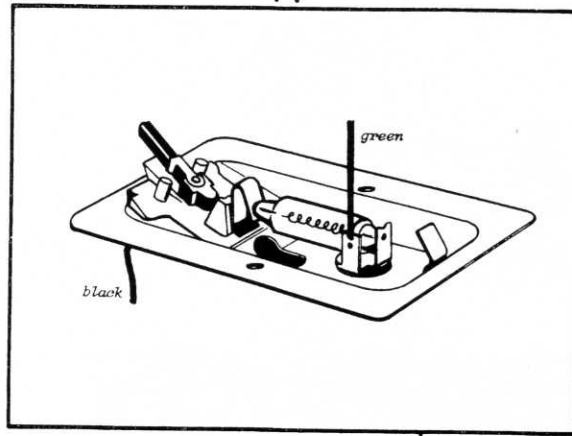

B

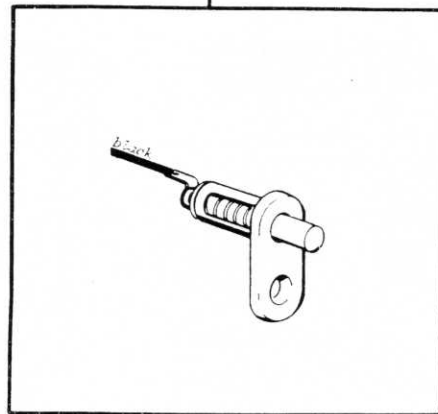

C

Interior light Coupe

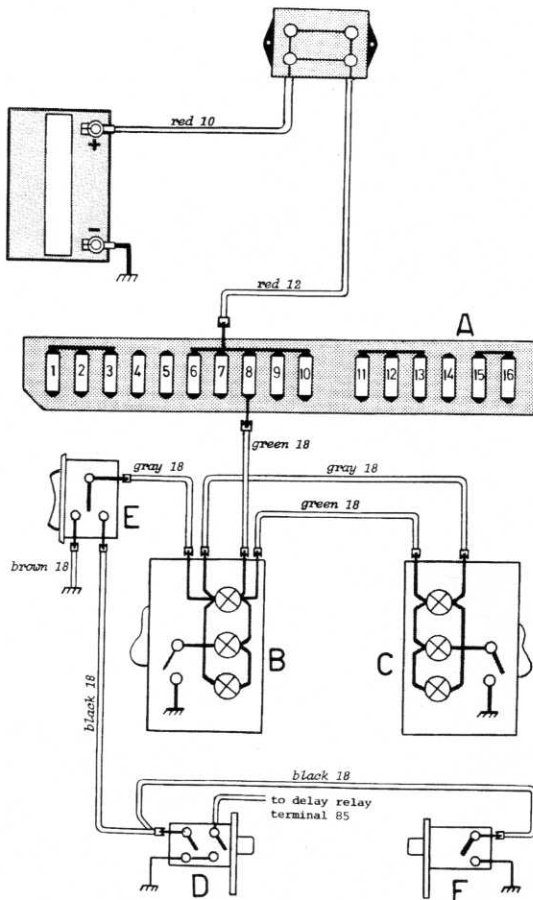

Fuse No. 8

- Clock
- Glove box light
- Interior light
- Hazard warning flasher

Legend:

- A Fuse box
- B Interior light, left side
- C Interior light, right side
- D Door switch, left door
- E Interior light switch
- F Door switch, right door

For connections at left side door switch also see "Delayed Interior Light".

Switch on steering column in POS 1. Light ON

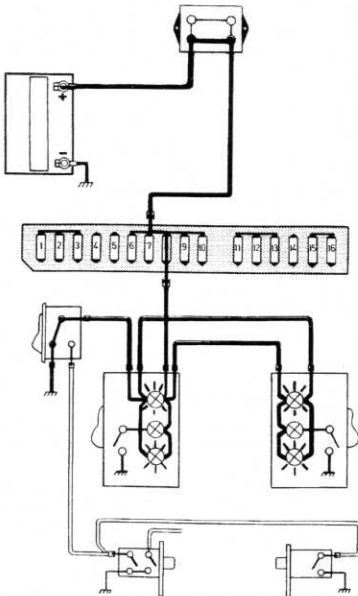

Switch on steering column in POS 2. Light ON with any door open.

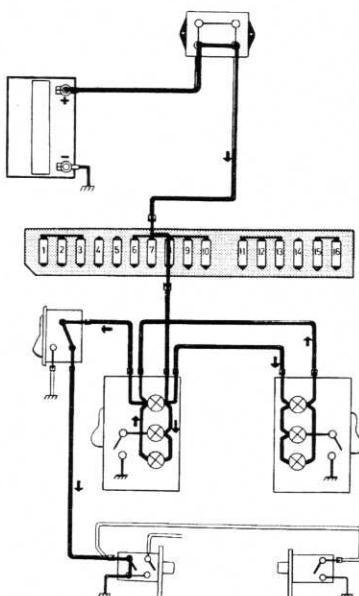

Lamp switch ON. Spotlights illuminated.

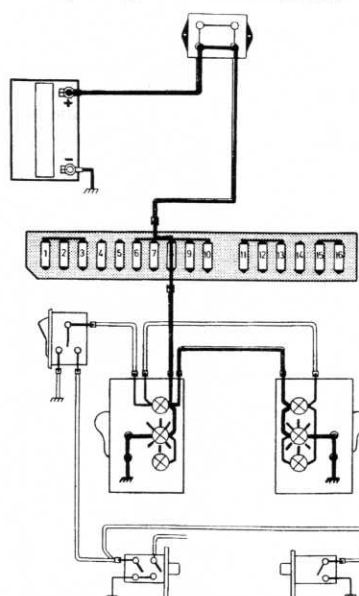

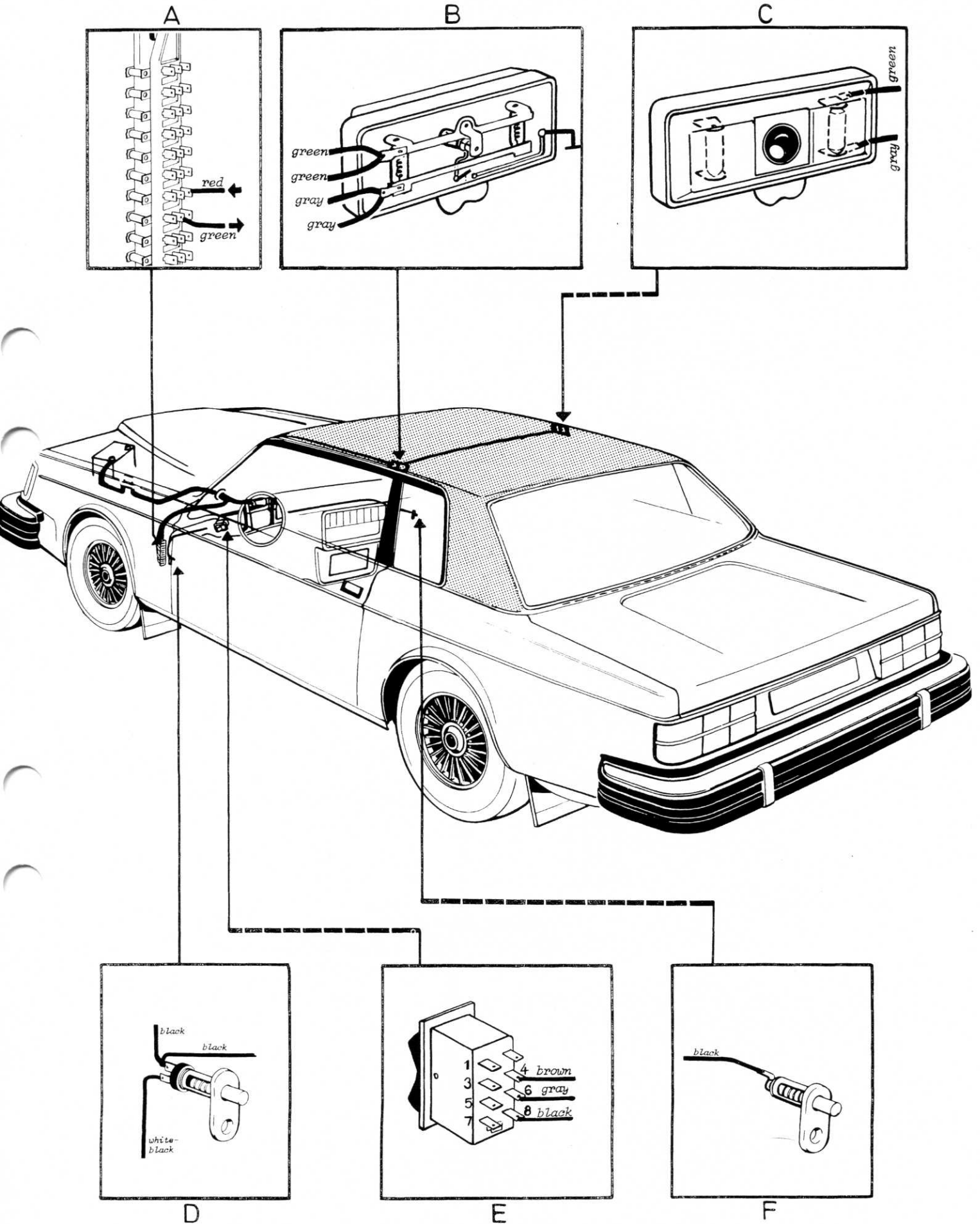

Engine compartment light, trunk light

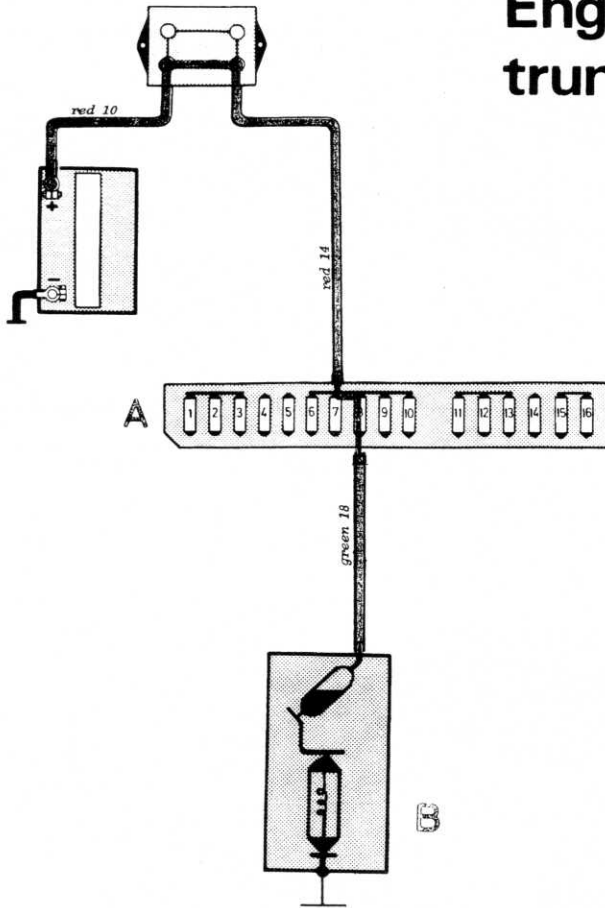

Fuse No. 8:
Interior light
Glove box light
Trunk light
Engine compartment light
Clock

Legend:
A Fuse box
B Engine compartment
light and/or trunk light

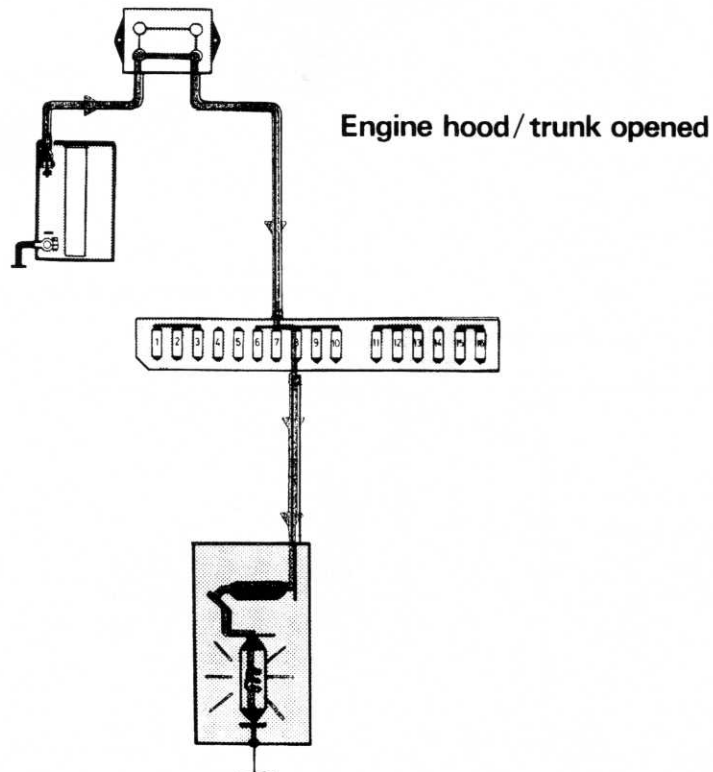

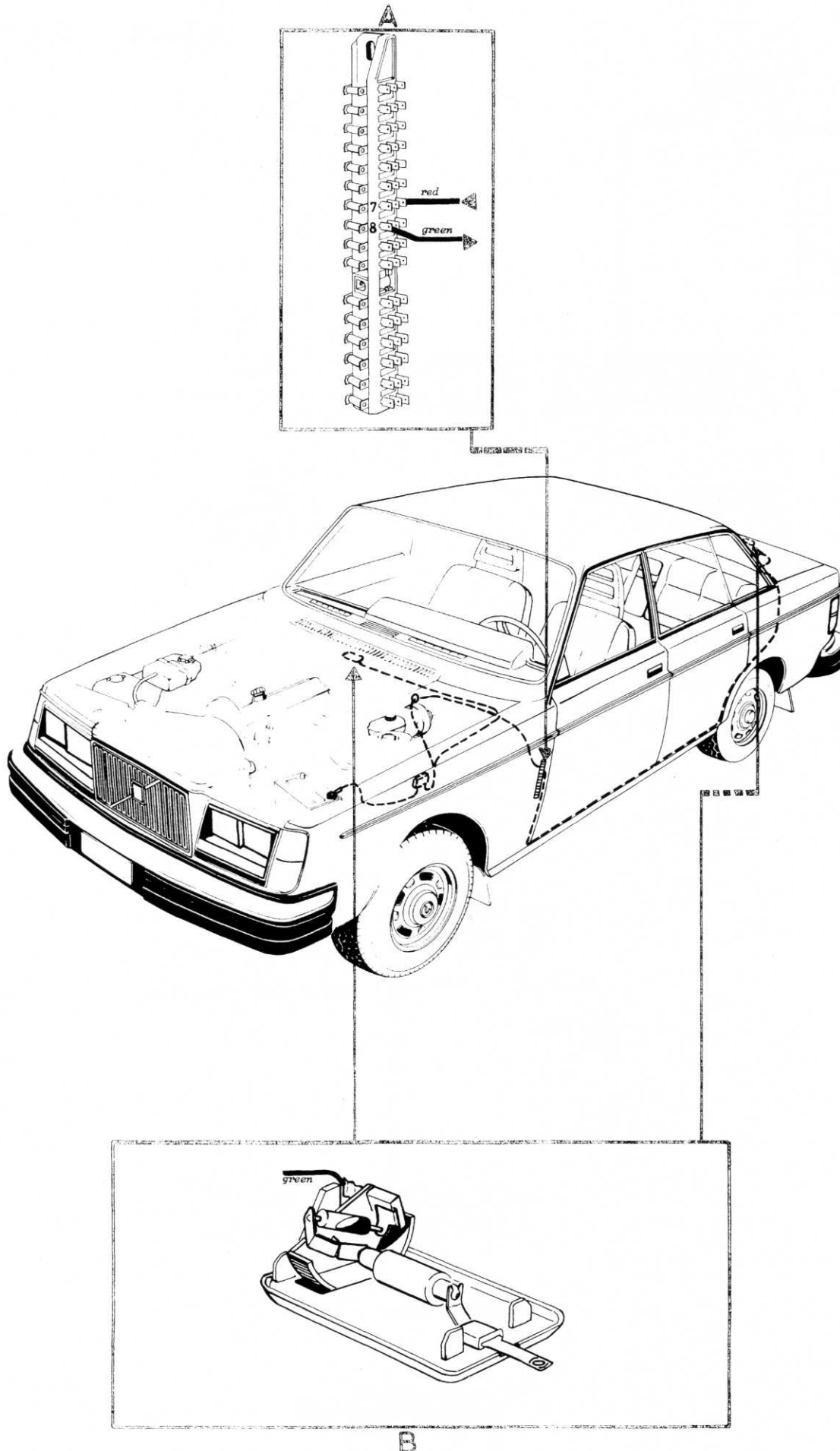

Glove box light

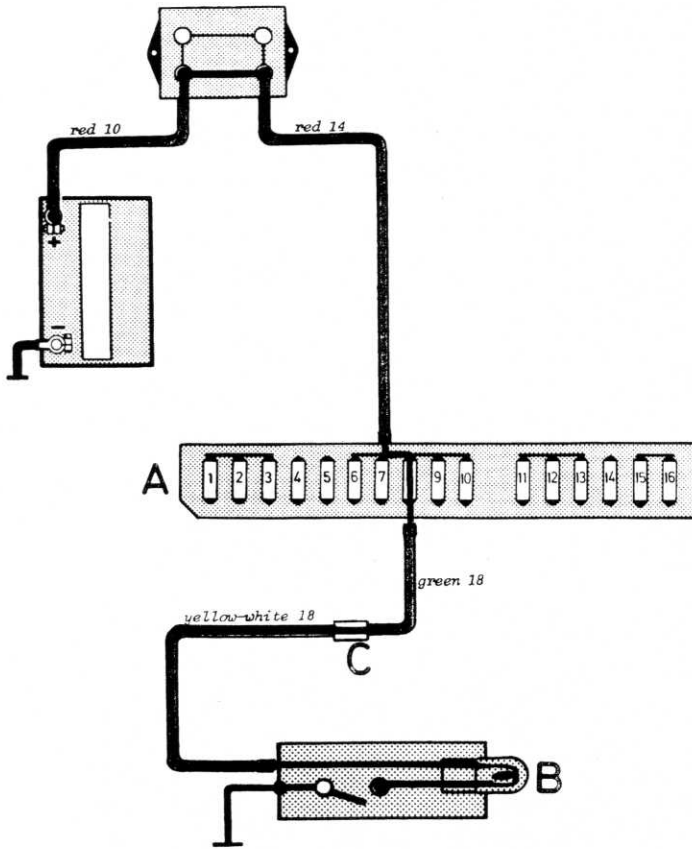

Fuse No. 8:
Interior light
Glove box light
Trunk light
Engine compartment light
Clock

Legend:
A Fuse box
B Glove box light
C Connector

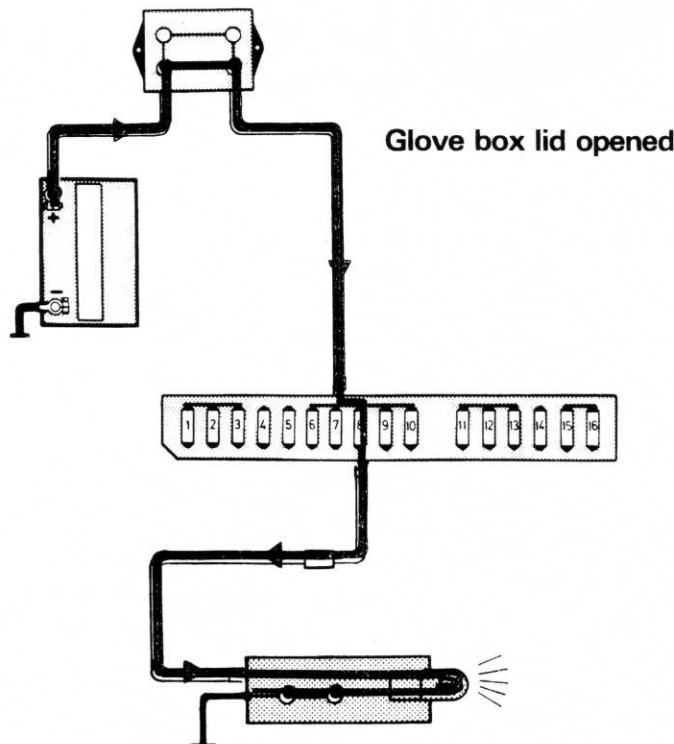

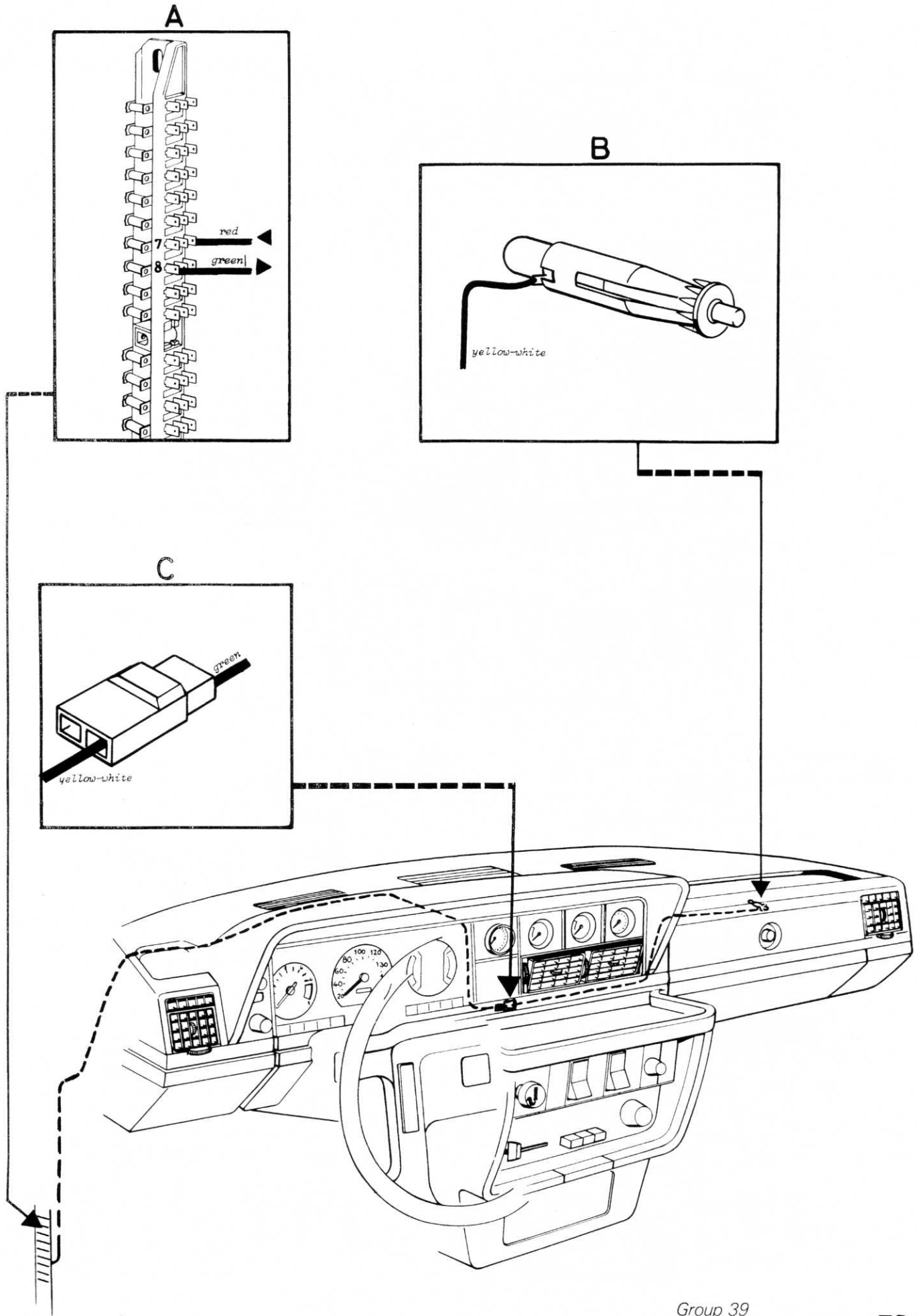

Instrument lights, lights on controls

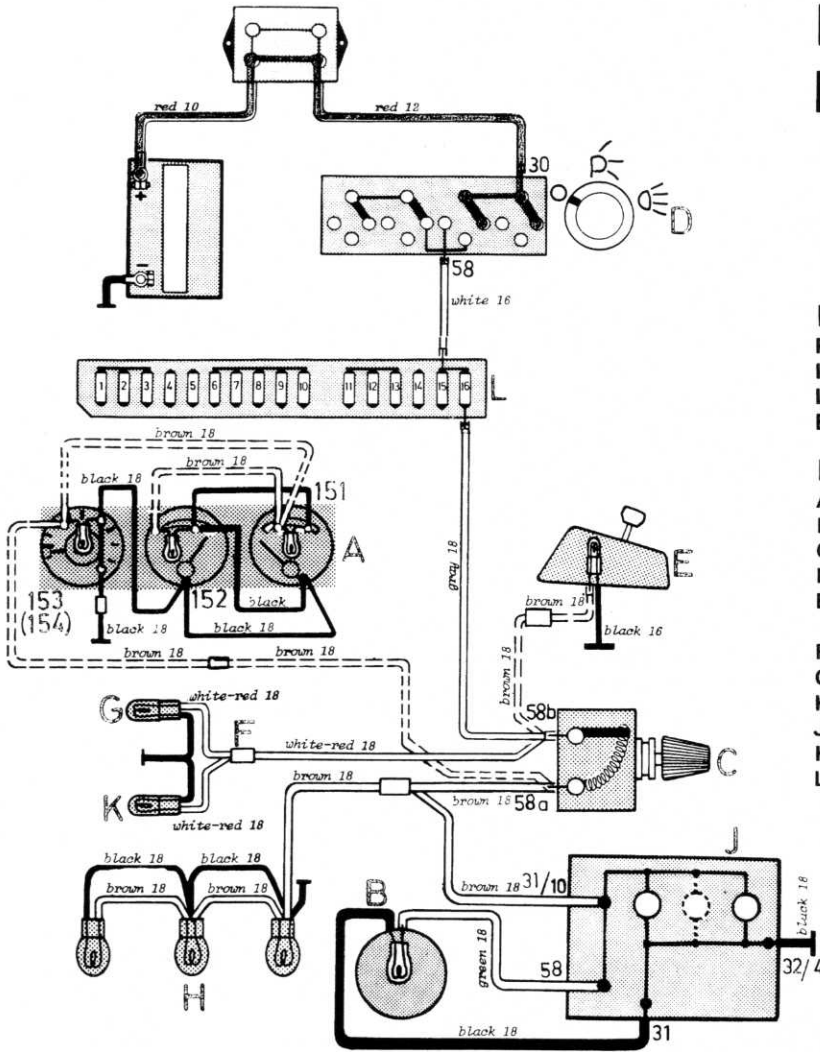

Fuse No. 16:
 Parking light, right side
 Instrument lights
 Lights on controls
 Buzzer, headlight

- Legend:**
- A Instrument lights
 - B Clock
 - C Rheostat
 - D Light switch
 - E Gear selector light
(automatic transmission)
 - F Connector
 - G Seat belt lock light
 - H Lights on controls
 - J Instrument lights
 - K Ash tray light
 - L Fuse box

Light switch ON.
Dimmed light.

Light switch ON.
Full light.

